



AC/DC

EDS3090/-91/-92/-96

Portable equipment for insulation fault location
for energised and deenergised AC and DC systems

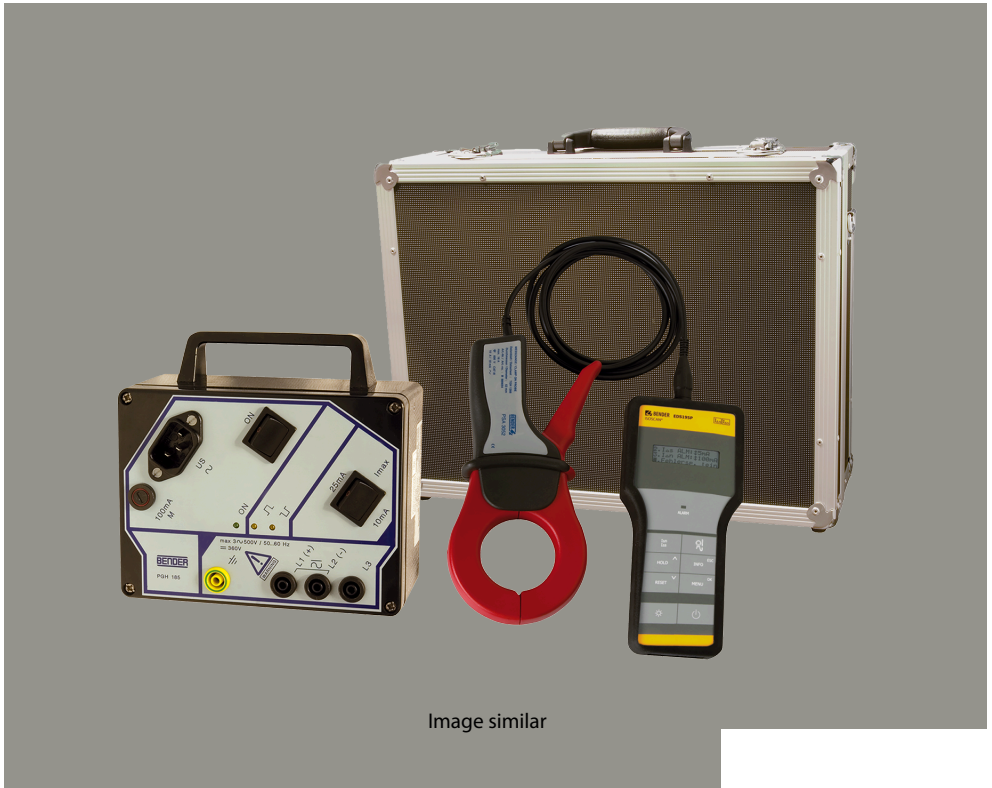

Image similar

Table of contents

1	General information.....	5
1.1	How to use the manual.....	5
1.2	Indication of important instructions and information.....	5
1.3	Service and Support.....	5
1.4	Training courses and seminars.....	5
1.5	Delivery conditions.....	5
1.6	Inspection, transport and storage.....	5
1.7	Warranty and liability.....	6
1.8	Disposal of Bender devices.....	6
2	Safety instructions.....	7
3	System description.....	8
3.1	Intended use.....	8
3.2	System components.....	8
3.2.1	Overview.....	8
3.2.2	Insulation fault location equipment type list.....	9
3.2.3	Accessories.....	11
3.3	Function of the system components.....	11
3.3.1	Locating current injector PGH18.....	11
3.3.2	Insulation fault locator EDS195P(M).....	11
3.3.3	Measuring clamps.....	12
3.3.4	Coupling device AGE185.....	12
3.4	Operating principle for insulation fault location ($I_{\Delta L}$).....	12
3.4.1	Schematic diagram EDS system.....	13
3.4.2	Test cycle.....	14
3.4.3	Definitions.....	14
3.4.4	Currents in the EDS system.....	14
3.5	Operating principle for residual current measurement ($I_{\Delta n}$).....	15
4	To consider before use.....	17
4.1	Functionality of equipment for insulation fault location.....	17
4.2	Requirements for reliable insulation fault location.....	17
4.3	Reduced locating current.....	19
4.4	Response sensitivity characteristics of the EDS195P(M).....	20
4.4.1	Response characteristics for main circuits in 3AC systems.....	21
4.4.2	Response characteristics for main circuits in AC systems.....	22
4.4.3	Response characteristics for main circuits in DC systems.....	23

4.4.4	Response characteristics for control circuits in AC systems.....	24
4.4.5	Response characteristics for control circuits in DC systems.....	25
5	Connecting the locating current injector.....	26
5.1	Disconnecting insulation monitoring device.....	26
5.2	Locating current injector in a de-energized IT system.....	26
5.3	Connection to a live IT system.....	27
5.4	Connection to a PV system.....	28
6	Operation.....	30
6.1	Short description of insulation fault location (EDS mode).....	30
6.2	Detailed description of insulation fault location.....	30
6.3	Description of a residual current measurement.....	31
6.4	Display and operating elements of the PGH18.....	31
6.5	Display and operating elements of the EDS195P(M).....	32
6.6	Operating the EDS195P(M).....	33
6.6.1	Switching on and off the device.....	33
6.6.2	Changing the measuring clamp.....	34
6.6.3	Switch on display lighting.....	34
6.6.4	Change between insulation fault location $I_{\Delta L}$ and residual current measurement $I_{\Delta n}$	34
6.6.5	Quickly check the response values for $I_{\Delta L}$ and $I_{\Delta n}$	34
6.6.6	Checking Info menu.....	34
6.6.7	Meaning of the display elements.....	35
6.7	Standard displays on the EDS195P(M).....	35
6.7.1	EDS measurement ($I_{\Delta L}$).....	35
6.7.2	RCM measurement ($I_{\Delta n}$).....	36
6.8	Alarms during EDS measurement or RCM measurement.....	37
6.9	Indication of device and measuring errors.....	37
6.10	Factory settings EDS195P(M).....	38
6.11	Menu structure.....	39
6.11.1	Navigating in the menu.....	40
6.11.2	Menu item 2. Settings.....	40
6.11.3	Menu item 3. System.....	40
6.11.4	Menu item 4. Harmonics.....	40
6.11.5	Menu item 5. $I_{\Delta L}$ alarms.....	41
6.11.6	Menu item 6. $I_{\Delta n}$ logger.....	41
6.12	Practical usage.....	41
6.12.1	Insulation fault location in a system without a permanently installed EDS system.....	41
6.12.2	Insulation fault location in a system with a permanently installed EDS system.....	43

6.12.3	Insulation fault location in diode-decoupled DC systems.....	45
6.12.4	Usage of the EDS195PM as a residual current meter.....	48
6.12.5	Indication of the harmonics during residual current measurement.....	49
6.13	Coupling device AGE185 for higher system voltages.....	49
6.14	Power supply for the EDS195PM.....	50
6.14.1	Displaying charge state.....	51
6.14.2	Changing batteries.....	51
6.14.3	Power supply unit supplied.....	51
6.15	Additional fault location information using the EDS309x.....	51
6.15.1	Collecting and analysing information.....	52
6.15.2	Taking measurements.....	52
7	Technical data.....	58
7.1	Technical data EDS309... system.....	58
7.2	Technical data PGH18.....	58
7.3	Technical data EDS195P(M).....	59
7.4	Technical data measuring clamps.....	61
7.5	Technical data AGE185.....	62
7.6	Standards and certifications.....	62
7.7	Dimension diagrams.....	63
7.8	Status word.....	64
7.9	Ordering details.....	65
7.10	Component list.....	66
7.11	Change log.....	66

1 General information

1.1 How to use the manual

**ADVICE**

This manual is intended for qualified personnel working in electrical engineering and electronics! Part of the device documentation in addition to this manual is the enclosed supplement "Safety instructions for Bender products".

**ADVICE**

Read the operating manual before mounting, connecting and commissioning the device. Keep the manual within easy reach for future reference.

1.2 Indication of important instructions and information

**DANGER**

Indicates a high risk of danger that will result in death or serious injury if not avoided.

**WARNING**

Indicates a medium risk of danger that can lead to death or serious injury if not avoided.

**CAUTION**

Indicates a low-level risk that can result in minor or moderate injury or damage to property if not avoided.

**ADVICE**

Indicates important facts that do not result in immediate injuries. They can lead to malfunctions if the device is handled incorrectly.



Information can help to optimise the use of the product.

1.3 Service and Support

Information and contact details about customer service, repair service or field service for Bender devices are available on the following website: www.bender.de/en/ > [Service & Support](#).

1.4 Training courses and seminars

Regular face-to-face or online seminars for customers and other interested parties:

www.bender.de/en/ > [Know-How](#) > [Seminars](#)

1.5 Delivery conditions

The conditions of sale and delivery set out by Bender GmbH & Co. KG apply. These can be obtained in printed or electronic format.

1.6 Inspection, transport and storage

Check the shipping and device packaging for transport damage and scope of delivery. In the event of complaints, the company must be notified immediately, see www.bender.de/en/ > [Service & Support](#).

When storing the devices, observe the information under Environment / EMC in the technical data.

1.7 Warranty and liability

Warranty and liability claims for personal injury and property damage are excluded in the case of:

- improper use of the device
- incorrect mounting, commissioning, operation and maintenance of the device
- Failure to observe the instructions in this operating manual regarding transport, commissioning, operation and maintenance of the device
- unauthorised changes to the device made by parties other than the manufacturer
- non-observance of technical data
- Repairs carried out incorrectly
- the use of accessories or spare parts that are not provided, approved or recommended by the manufacturer
- Catastrophes caused by external influences and force majeure
- Mounting and installation with device combinations not approved or recommended by the manufacturer

This operating manual and the enclosed safety instructions must be observed by all persons working with the device. Furthermore, the rules and regulations that apply for accident prevention at the place of use must be observed.

1.8 Disposal of Bender devices

Abide by the national regulations and laws governing the disposal of this device.



Bender GmbH & Co. KG is registered in the waste from electrical and electronic equipment (WEEE) register under the WEEE number: DE 43 124 402. For more information on the disposal of Bender devices, refer to [Bender.de/en/ > Service & Support](https://www.bender.de/en/>Service%20%26%20Support).

2 Safety instructions

If the device is used outside the Federal Republic of Germany, the applicable local standards and regulations must be complied with. In Europe, the European standard EN 50110 applies.



DANGER

Risk of fatal injury due to electric shock!

Touching live parts of the system carries the risk of:

- *Risk of electrocution due to electric shock*
- *Damage to the electrical installation*
- *Destruction of the device*

Before installing the device and before working on its connections, make sure that the installation has been de-energised. The rules for working on electrical systems must be observed.

Hazard due to excessively high locating current or locating voltage

An excessively high PGH18... locating current may damage sensitive loads (e.g. in control circuits) or trigger unintended switching processes. For this reason select a lower locating current for these systems (1 mA or 10 mA).

For instance it is only allowed to use the EDS3091 or EDS3091PG in systems with programmable logic controllers (PLCs).

The locating voltage of DC 50 V produced by the locating current injector PGH186 can cause interference at sensitive system components. In case of doubt, contact Bender.

The locating current from the PGH185 or PGH186 can cause residual current devices to trip. The locating current is limited to maximum 25 mA (or 10 mA), however 30 mA residual current devices may trip, for instance, between 15 mA and 30 mA.

Inaccurate measurement

System interference and high system leakage capacitances can degrade the accuracy of the measurement.

Alarm due to insufficient conductor symmetry



It is necessary to aim for the best possible conductor symmetry in the measuring clamp. Otherwise the measuring clamp may go into saturation due to an excessively high load current and cause an alarm $I_{\Delta n} > 10 \text{ A}$.

3 System description

3.1 Intended use



Only skilled persons are permitted to carry out the work necessary to install, put into service and run a device or system.

The portable insulation fault location system EDS309... is used to locate insulation faults in IT systems. All variants are suitable for the measurement of residual currents in TN and TT systems. The EDS3096PG is particularly suitable for insulation fault location in electrically isolated systems.

Please observe the limits on the area of application stated in the technical specifications, as well as the measuring categories for the measuring clamps used. If, in the specific case, measuring current transformers other than the measuring clamps supplied are used with the EDS195P(M), adequate nominal insulation voltage must be ensured for the connection wires and transformer (overvoltage category, see Technical data).

Do not make any unauthorised changes to the device. Only use spare parts and optional accessories sold or recommended by the manufacturer.

Any other use than that described in this manual is regarded as improper.

3.2 System components

A detailed overview of the scope of delivery of the EDS309x variants can be found at "Ordering details", page 65.

3.2.1 Overview

The primary task of the EDS309... is insulation fault location in IT systems. For this purpose the individual components of the EDS309... are used in combination.

Choice of the possible components

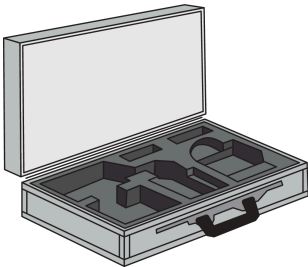

Aluminium case with handle

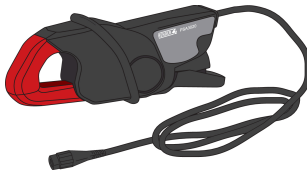

Measuring clamp
PSA3020 (main circuits) or
PSA3320 (control circuits)
Inside diameter: 20 mm



Measuring clamp
PSA3052 (main circuits) or
PSA3352 (control circuits)
Inside diameter: 52 mm

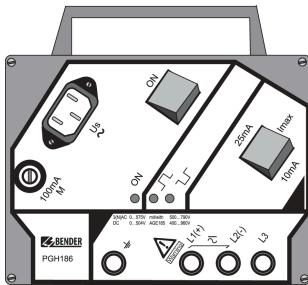

Locating current injector PGH18...
For generating a locating current for
insulation fault location



Insulation fault locator EDS195P(M)
For connecting measuring clamps and
for finding insulation faults

3.2.2 Insulation fault location equipment type list

Residual current measurement is possible in TT and TN systems (earthed systems) using the device variants listed below. The following overview describes which tasks can be done with which models.

Equipment for insulation fault location in main circuits

1. Permissible system voltage in the main circuits:

- Insulation fault location in IT systems up to AC 42...460 Hz, 20...575 V and DC 20...504 V
- Insulation fault location using AGE185 up to AC 42...460 Hz, 500...790 V and DC 400...960 V

EDS3090:

- Can be used in IT systems in which a locating current injector (e.g. PGH471) or an ISOMETER® with integrated locating current injector (e.g. iso685-x-P) is already installed.

EDS3090PG:

- Can be used in IT systems in which no locating current generator and no ISOMETER® with integrated locating current generator is installed.
- Supply voltage for the locating current generator PGH185 supplied: AC 50...60 Hz, 230 V

EDS3090PG-13:

- Can be used in IT systems in which no locating current generator and no ISOMETER® with integrated locating current generator is installed.
- Supply voltage for the locating current generator PGH185-13 supplied: AC 50...60 Hz, 90...132 V

2. Permissible system voltage in the main circuits:

- Insulation fault location in IT systems up to AC 42...460 Hz, 0...575 V and DC 0...504 V
- Insulation fault location using AGE185 up to AC 42...460 Hz, 500...790 V and DC 400...960 V

EDS3096PG:

- Can be used in IT systems in which no locating current generator and no ISOMETER® with integrated locating current generator is installed.
- Supply voltage for the locating current generator PGH186 supplied: AC 50...60 Hz, 230 V
- Insulation fault location, also in IT systems electrically isolated on all poles

EDS3096PG-13:

- Can be used in IT systems in which no locating current generator and no ISOMETER® with integrated locating current generator is installed.
- Supply voltage for the locating current generator PGH186-13 supplied: AC 50...60 Hz, 90...132 V
- Insulation fault location, also in IT systems electrically isolated on all poles

EDS3096PV:

- Applicable in PV systems without a locating current injector installed
- Supply voltage for the delivered locating current injector PGH186: AC 50...60 Hz, 230 V
- Insulation fault location, also in IT systems disconnected on all poles or in de-energised IT systems

Accessories CTAF:

- Set with flexible clamps with band lengths of 500 and 1000 mm
- Application for cables with big dimensions or in systems with narrow space conditions
- Combinable with EDS3090, EDS3092, EDS3096
- The minor response sensitivity towards the clamps PSA3... in chapter "Response sensitivity characteristics of the EDS195P(M)", page 20 must be considered.

Equipment for insulation fault location in control circuits

Permissible system voltage in the control circuits:

- Insulation fault location in IT systems up to AC 42...460 Hz, 20...265 V and DC 20...308 V

EDS3091:

- Can be used in IT systems in which a locating current injector (e.g. PGH473) or an ISOMETER® with integrated locating current injector (e.g. iso685-x-P) is already installed.

EDS3091PG:

- Can be used in IT systems in which no locating current generator and no ISOMETER® with integrated locating current generator is installed.
- Supply voltage for the locating current generator PGH183 supplied: AC 50...60 Hz, 230 V

EDS3091PG-13:

- Can be used in IT systems in which no locating current generator and no ISOMETER® with integrated locating current generator is installed.
- Supply voltage for the locating current generator PGH183-13 supplied: AC 50...60 Hz, 90...132 V

Equipment for insulation fault location in main circuits and control circuits**EDS3092PG:**

- Contains the components and combines the features of the EDS3090PG and EDS3091PG

3.2.3 Accessories

You will find information on the standard accessories as well as on optional accessories in "Ordering details", page 65 and in "Component list", page 66.

i *When working with the EDS309..., only use the components supplied by us. Commercially available measuring clamps must not be used! This also applies to measuring clamps or measuring current transformers from the Bender range that are not expressly intended for use with the EDS309....*

In addition to the measuring clamps supplied, the following measuring current transformers from the Bender series may be connected to the EDS195P(M):

- WF...
- W... /WR... /WS...
- W...-8000/WS...-8000

Series W...AB current transformers cannot be used!

For series WF... current transformers you will need a BNC to PS2 adapter cable, see "Ordering details", page 65.

3.3 Function of the system components

3.3.1 Locating current injector PGH18...

The PGH18... generates a defined locating current. The current depends on the insulation fault and the system voltage.

- The PGH185 or PGH186 limits the locating current to maximum 25 mA or maximum 10 mA depending on the switch setting.
- The PGH183 limits the locating current to maximum 2.5 mA or maximum 1 mA depending on the switch setting.
- The PGH186 applies the locating current in electrically isolated IT systems or in IT systems with a system voltage < 50 V using an integrated voltage source (DC 50 V). In IT systems with a system voltage > 50 V the existing voltage in the system is used to drive the locating current.

3.3.2 Insulation fault locator EDS195P(M)

Measuring functions

- Insulation fault location $I_{\Delta L}$ (EDS mode) for use in IT AC or DC systems:
 - Either as a component of the portable equipment for insulation fault location EDS309...
 - Or as an additional insulation fault locator in permanently installed equipment for insulation fault location with IRDH575, iso685-x-P or isoxx1685xP or PGH1... as well as EDS4...
 - EDS195PM - only devices with the suffix "M" have the measuring signal output for connecting an oscilloscope
- Residual current measurement $I_{\Delta n}$ (mode) for usage in TN or TT AC systems.

Response value

The response value is defined by the sensitivity of the EDS195P(M). This value can be set in both DC and (3)AC IT systems as an arithmetic mean, see "Measuring clamps", page 12. System interference and high system leakage capacitances can degrade the accuracy.

3.3.3 Measuring clamps

Measuring clamps measure the locating current or the residual current. They have a test lead approx. 2 m long. They are connected to the EDS195P(M) via a BNC connector. The following table summarises the most important data for the usage of the different measuring clamps.

Measuring clamps and response values for the EDS195P(M)

		Main circuit (EDS3090..., 3092..., 3096...)		Control circuit (EDS3091...)
IT system	Meas. clamps	PSA3020, PSA3052, PSA3165	CTAF	PSA3320, PSA3352
	Meas. range	2...50 mA	10...50 mA	0.2...5 mA
	Response value	2...10 mA, $\pm 30\%$ / ± 2 mA	10 mA, $\pm 30\%$ / ± 2 mA	0.2...1 mA, $\pm 30\%$ / ± 0.2 mA
TN/TT system	Meas. clamps	PSA3020, PSA3052, PSA3165		PSA3320, PSA3352
	Meas. range	5 mA ... 10 A		2 mA ... 2 A
	Response value	10 mA ... 10 A		5 mA ... 1 A

If measuring current transformers are used instead of measuring clamps, you will need the adapter supplied: BNC/4-mm connector. See "Component list", page 66.

3.3.4 Coupling device AGE185

The coupling device AGE185 expands the nominal voltage range of the equipment for insulation fault location EDS309.... It enables the equipment to be connected to system nominal voltages up to AC 790 V or DC 960 V.

3.4 Operating principle for insulation fault location ($I_{\Delta L}$)

On the occurrence of the first insulation fault in IT systems a residual current flows that is essentially defined by the system leakage capacitances. The basic concept of fault location is therefore to briefly close the fault circuit using a defined resistance. With this principle a locating current is provided by the system voltage and this locating current contains a signal that can be evaluated.

The locating current is generated periodically by the locating current injector PGH18... (part of the EDS309... PG system). The locating current can also be generated by an iso685-D-P, isoxx1685xP, IRDH575 or a locating current injector PGH47...

The locating current is limited in amplitude and time. In this process, the system conductors are alternately connected to earth via a defined resistance. The resulting test current depends on the size of the insulation fault and the system voltage.

For example the locating current on the EDS3090 is limited to maximum 25 mA; with the setting $I_{\max} = 10$ mA it is limited to 10 mA. When planning ensure that there are no system components in which this locating current could cause damage.

The locating current pulse flows from the locating current injector through the live conductors to the insulation fault by the shortest route. From there it flows via the insulation fault and the earth cable (PE cable) back to the locating current injector. This locating current pulse is detected by the measuring clamps or measuring current transformers in the insulation fault path and is indicated by the insulation fault locator EDS195P(M) connected.

- i** Observe these notes for a correct measurement result:
- Route all live conductors through the measuring clamp.
 - Do not route any protective earth conductors or screens on screened cables through the measuring clamp.
 - Do not use commercial measuring clamps. They are not suitable for the EDS309...

You will find additional information in our technical information Techinfo08 "Transformer installation".

3.4.1 Schematic diagram EDS system

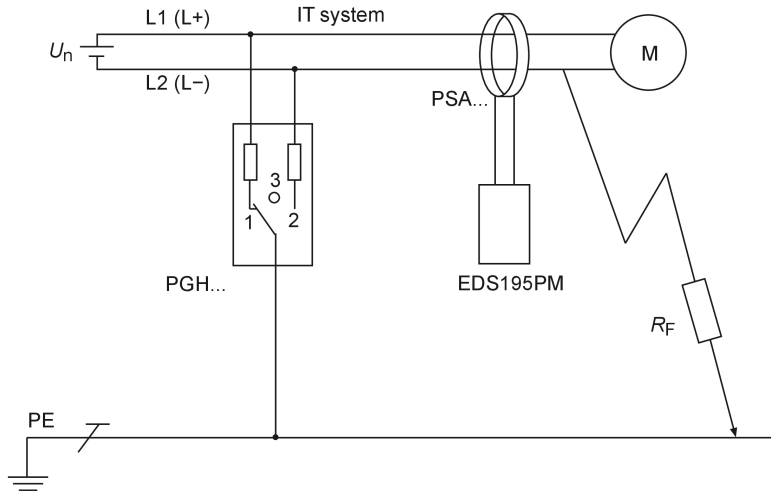

EDS195P(M)	Insulation fault locator
PGH...	Locating current injector
U_n	IT system voltage
PSA...	Measuring clamp
R_F	Insulation fault
PE	Protective earth conductor

3.4.2 Test cycle

The locating current pulse cycle has a duration of 6 seconds. The PGH... sends alternating positive and negative locating current pulses. The sketch below shows the test cycle of the PGH... with the different switch settings (1, 2, 3) on the device.

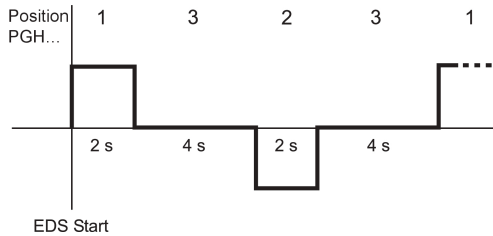

3.4.3 Definitions

I_L Locating current that flows through the locating current injector while the fault location is running (EDS mode)

$I_{\Delta L}$ Locating current measured by the insulation fault locator (EDS mode)

$I_{\Delta n}$ Residual current produced by an insulation fault (RCM mode)

3.4.4 Currents in the EDS system

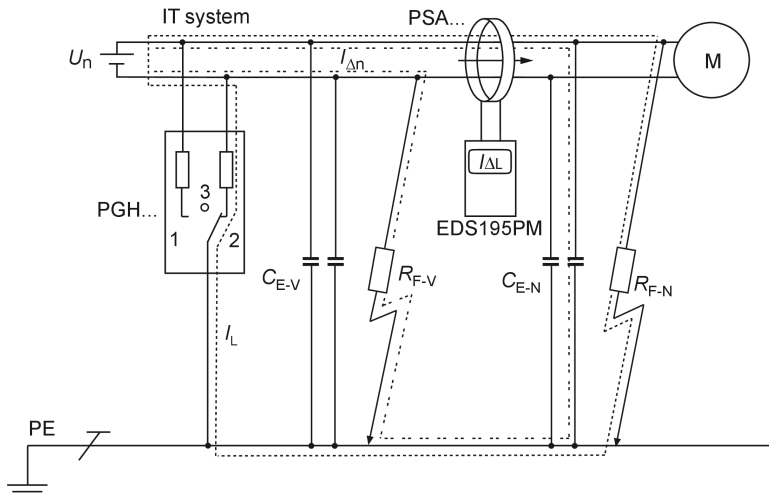

Figure 3-1: Path of the residual currents and the locating current

- Locating current circuit due to the insulation fault R_{F-N}
- Residual currents $I_{\Delta n}$ (example)
- $I_{\Delta L}$ Locating current measured by the EDS195P(M)
- C_{E-V} Upstream capacitances, system leakage capacitances upstream of the measuring current transformer

- C_{E-N}** Downstream capacitances, system leakage capacitance downstream of the measuring current transformer
- R_{F-V}** Insulation fault upstream of measuring current transformer
- R_{F-N}** Insulation fault downstream of the measuring current transformer

The following currents flow through the measuring current transformer of the EDS195P(M):

- The locating current caused by the insulation fault R_{F-N}
- The residual currents $I_{\Delta n}$ that flow through the system leakage capacitances C_{E-V} and C_{E-N} or that are caused by R_{F-V} and R_{F-N}
- Transient leakage currents that are caused by switching and control activities in the system
- Low-frequency leakage currents generated by the use of converters

3.5 Operating principle for residual current measurement ($I_{\Delta n}$)

In RCM mode the EDS309... operates based on the principle of residual current measurement. In this case only the insulation fault locator EDS195P(M) and a measuring clamp are used, the locating current injector PGH18... is not required. As per Kirchhoff's law the sum of the currents flowing into any node in a network is equal to the sum of the currents flowing out

The two currents I_1 and I_2 are equal in magnitude but different in sign, so that the sum is zero. The EDS195P(M) recognises this and shows no message.

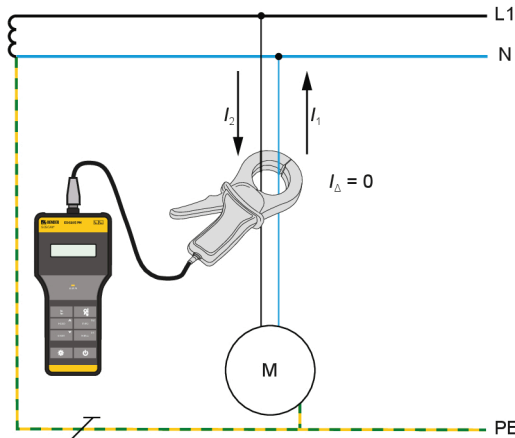

Part of the current flows through an insulation fault R_F . The sum of the two currents is no longer zero. As soon as the residual current reaches or exceeds the response value, the EDS195P(M) shows an alarm message.

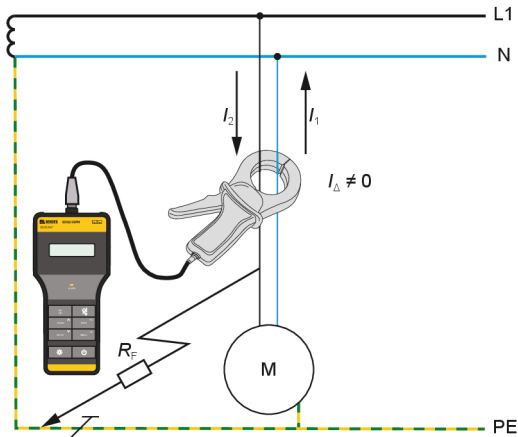

i In RCM mode it is possible to measure residual currents in single and three-phase TT or TN systems. If the system leakage capacitance ahead of the measuring clamp is sufficiently high, the EDS195P(M) can also be used for measurements in single and three-phase IT systems. The suitability of the device is to be checked in the specific case.

4 To consider before use

4.1 Functionality of equipment for insulation fault location

The equipment comprises a locating current injector PGH18... and an insulation fault locator EDS195P(M) with measuring clamp PSA3... connected.

Functional sequence

- Insulation fault location is started by activating the locating current injector PGH18...
- The locating current injector PGH18... briefly connects the live conductors to earth with current limiting.
- The insulation fault creates a closed circuit in which a locating current I_L , dependent on the system voltage, flows. The locating current is limited to max. 25 mA or 10 mA for PGH185/186 and 2.5 mA or 1 mA for PGH183.
- The locating current flows from the locating current injector via the live cables, the insulation fault R_F and the earth cable (PE cable) back to the locating current injector.
- The locating current signal can be measured using a measuring clamp placed around the cables in the outgoing circuit from the distribution system and evaluated by the insulation fault locator EDS195P(M).
- The location of the fault can be determined exactly by moving along the cable with the measuring clamp.

EDS operating principle

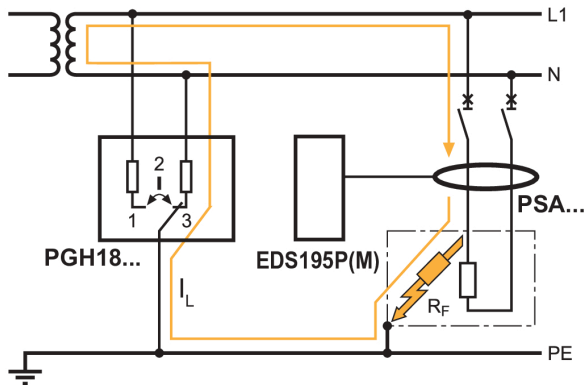

4.2 Requirements for reliable insulation fault location

The insulation fault locator has the task of locating the insulation fault $R_{F,N}$ downstream of the measuring clamp. For this purpose, it must reliably detect the locating current caused by the insulation fault.

Requirements

- The insulation fault must be present for at least 30s.
- The locating current is in the following ranges:
 - Main circuits with EDS3090, EDS3090PG, EDS3090PG-13, EDS3092PG, EDS3096PG-13, EDS3096PV, EDS3096PG:
 $I_L = 2 \dots 50$ mA
 - Control circuits with EDS3091, EDS3091PG, EDS3091PG-13, EDS3092PG:
 $I_L = 0.2 \dots 5$ mA

- The upstream capacitances C_{E-V} must be at least as large as the downstream capacitances C_{E-N} . See also "Currents in the EDS system", page 14.
- The total system leakage capacitance must not exceed the maximum values in the characteristics in chapter 4.4.
- The sum of the locating current and residual current flowing through the measuring clamp or the measuring current transformer must not exceed the following values:
 - Main circuits with EDS3090, EDS3090PG, EDS3090PG-13, EDS3092PG, EDS3096PG-13, EDS3096PV, EDS3096PG: maximum 10 A
 - Control circuits with EDS3091, EDS3091PG, EDS3091PG-13, EDS3092PG: maximum 1 A
- There must be no connections to other outgoing circuits downstream of a measuring clamp or measuring current transformer, see sketch.

Connections between outgoing circuits will result in measuring errors.

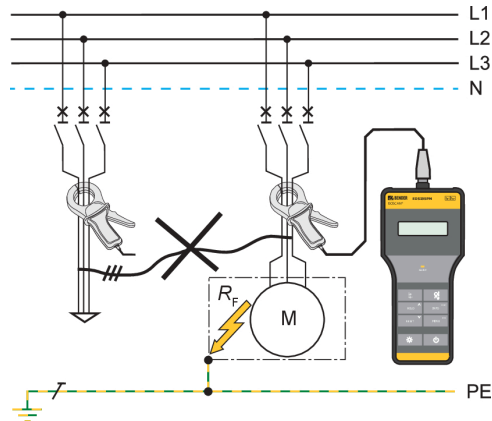

- As well as the magnitude of the residual current, the frequency of the residual current also affects the reliable detection of the locating current. Residual currents at frequencies other than the system frequency may, e.g., be caused by the usage of frequency converters. The behaviour of the EDS309... is described by the fault curve shown below:
 - **Main circuits:** If the measured residual current exceed 10 A, the EDS195P(M) outputs the alarm message $I_{\Delta n} > 10A$ aus. This applies to the system frequencies 50/60/400 Hz for the EDS3090, EDS3090PG, EDS3090PG-13, EDS3092PG, EDS3096PG-13, EDS3096PV and EDS3096PG.
 - **Control circuits:** If the measured residual current exceed 1 A, the EDS195P(M) outputs the alarm message $I_{\Delta n} > 1A$ aus. This applies to the system frequencies 50/60/400 Hz for the EDS3091, EDS3091PG, EDS3091PG-13 and EDS3092PG.

Fault curve:

A residual current of 2 A at 10 Hz is outside the permitted frequency range (red dot)
 → a valid measurement is not possible!

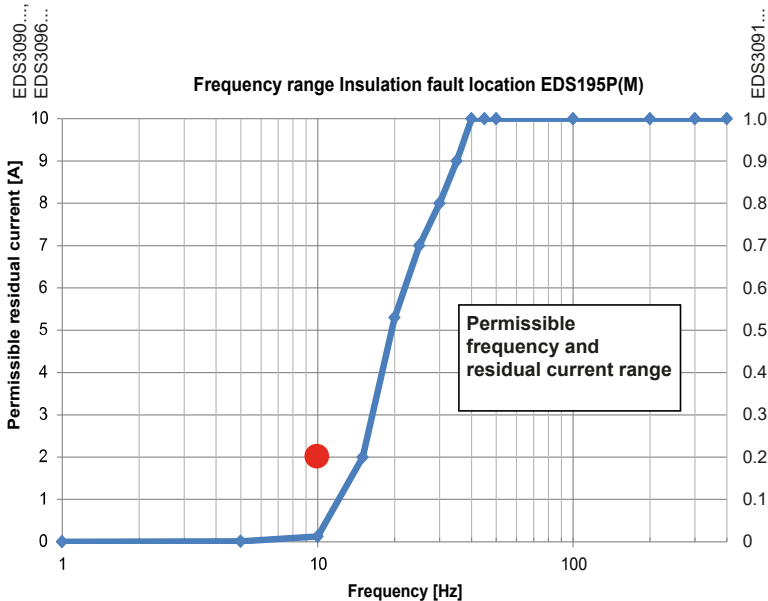

- i** There must be no connections between outgoing circuits downstream of the measuring clamp because such connections will produce interfering residual currents.
 For example, the message $I_{\Delta n} > 10A$ may be output as a consequence.
- i** Symmetrical insulation faults downstream of the measuring current transformer will not be detected in certain circumstances. Low frequency residual currents (e.g. caused by converters) can mean that insulation faults are not found if their frequency is the same as or approximately the same as the frequency of the locating cycle of the PGH18...
- i** Parallel cables routed to the same load are to be routed together through the measuring clamp during the measurement.

4.3 Reduced locating current

Particularly in DC control voltage systems in the power station and public utility sector there may be relays or PLCs installed that switch at relatively low currents. In such a case the **I_{max}** switch on the PGH18... must be placed in the **10 mA** or **1 mA** position. The switch's label, e.g. **10 mA** or **25 mA**, defines the magnitude of the locating current only for DC systems.

For AC locating currents see "Response sensitivity characteristics of the EDS195P(M)", page 20.

Before measuring with the reduced locating current (switch position **10 mA** or **1 mA**), it is also necessary to check whether sensitive system components could be unintentionally triggered.

4.4 Response sensitivity characteristics of the EDS195P(M)

The EDS system's response sensitivity is affected by

- the type of system,
- system voltage,
- system frequency,
- system leakage capacitance and
- locating current.

The magnitude of the locating current can be set on the locating current injector PGH18... A reduced locating current is produced in AC systems depending on the type of system. In comparison to DC systems the related factor in AC systems is 0.5 and in 3AC systems 0.67. For this reason, set the response value on the EDS195P(M) for usage in AC and 3AC systems as follows:

Settings for the EDS195P(M) and the PGH18...

Settings	Main circuit	Control circuit	PV system
Equipment for insulation fault location	EDS3090 EDS3090PG EDS3090PG-13 EDS3092PG EDS3096P	EDS3091 EDS3091PG EDS3091PG-13 EDS3092PG	EDS3096PV
EDS195P(M) setting: select the measuring clamp type using button	PSA 3020 , PSA 3052 , PSA3165 Measuring range 2...50 mA	PSA 3320 , PSA 3352 Measuring range 0.2...5 mA	PSA 3052 Measuring range 2...50 mA
PGH18... setting: locating current I_L	25 mA (PGH185/186)	2.5 mA (PGH183)	25 mA (PGH186)
Response range EDS195P(M) Menu item 2.2: I_{AL} ALM	2...10 mA	0.2...1 mA	2...10 mA
PGH18... setting: reduced locating current I_L	10 mA (PGH185/186)	1 mA (PGH183)	10 mA (PGH186)
Response range EDS195P(M) with reduced locating current Menu item 2.2: I_{AL} ALM	2...5 mA	0.2...0.5 mA	2...5 mA

For the response value setting see menu item **2. Settings > 2. I_{AL}** ("Menu structure", page 39). The response values are given as characteristics that can have a maximum error of $\pm 30\%$. Measuring clamp tolerances are included here. The characteristics apply at the related nominal voltage stated.

In case of variation in the nominal voltage, a proportional change in the response values is to be expected. In case of system voltages that change dynamically or in case of superimposed DC currents and AC currents that vary from the system frequency (e.g. due to frequency converters), response values outside the ranges shown may result.

The characteristics below enable you to simply determine a practical response value for the EDS195P(M). If the insulation monitoring device in a monitored system indicates an alarm message, manual insulation fault location can be started.

Proceed as follows:

1. Select the characteristics (3AC, AC, DC) that are appropriate for your type of system.
2. From these, select the diagram that best matches the desired system voltage.
3. Calculate the expected leakage capacitance C_e of the system monitored. Insulation monitoring devices in the IRDH... series can indicate the magnitude of the leakage capacitance (press **INFO** button). Apply this value to the diagram in the form of a vertical line. If it is not possible to check the capacitance, choose the highest capacitance in the related diagram.
4. The characteristics shown indicate the response sensitivity of the EDS195P(M) in main circuits for 2 mA, 5 mA and 10 mA and in control circuits for 0.2 mA, 0.5 mA and 1 mA. Values above the related curve cannot be measured. Values and characteristics that lie in the area between the upper and lower characteristic can be estimated approximately using the existing characteristics.
5. On the EDS195P(M), set the required response value on the left of the line from step 3.

i *The characteristics for DC 24 V and AC 42 V do not apply to the EDS3096, as the locating current generator operates with a locating voltage of DC 50 V. For this reason the curves for DC 60 V and AC 110 V apply at these nominal voltages.*

4.4.1 Response characteristics for main circuits in 3AC systems

i *When using CTAF-SET, only the 10 mA characteristics apply.*

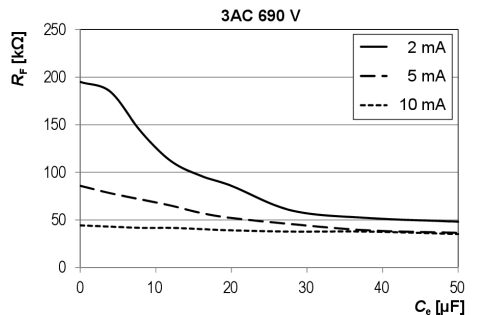
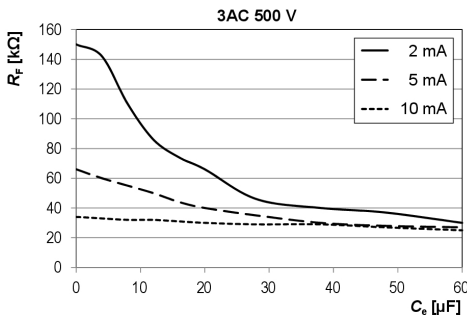
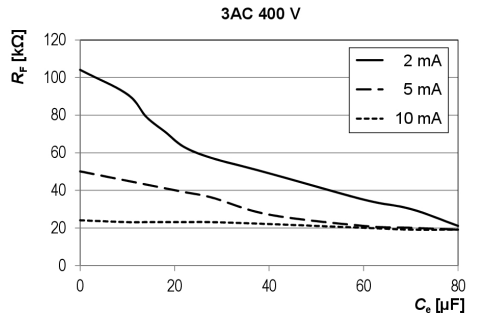
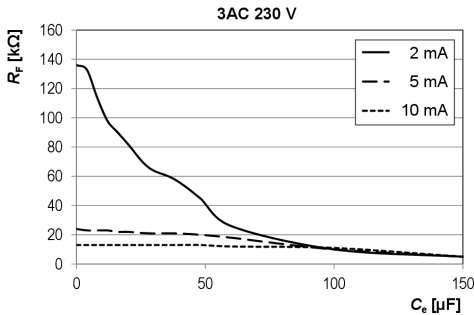

4.4.2 Response characteristics for main circuits in AC systems

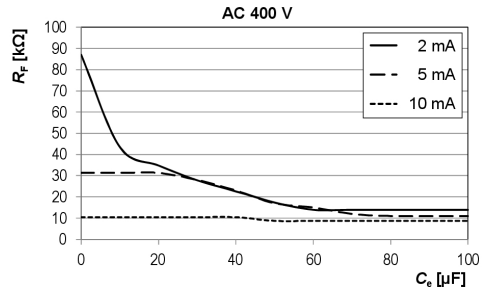
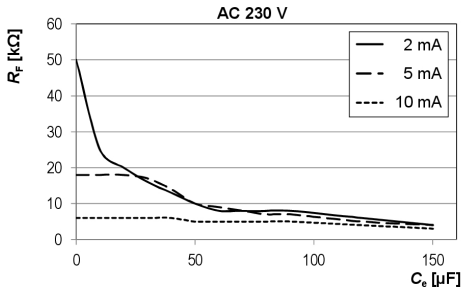
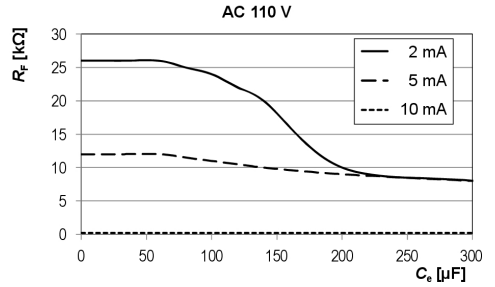
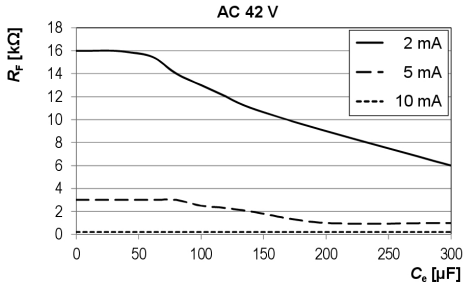

4.4.3 Response characteristics for main circuits in DC systems

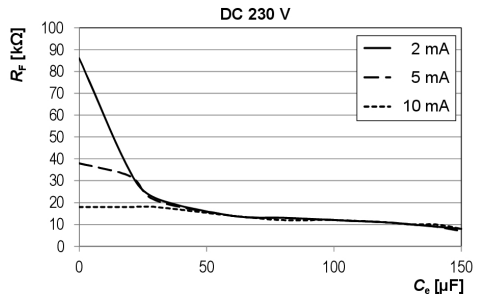
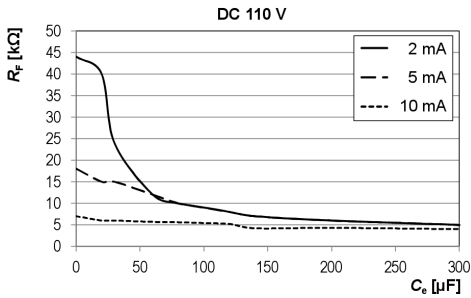
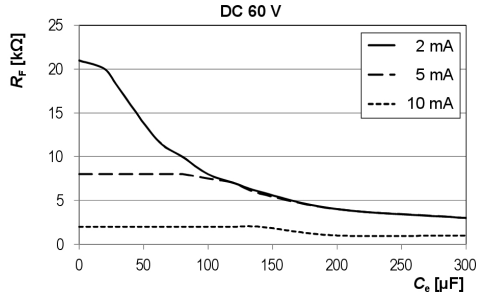
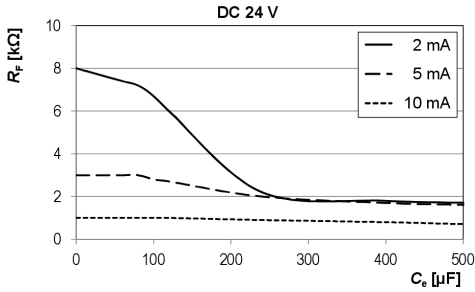

4.4.4 Response characteristics for control circuits in AC systems

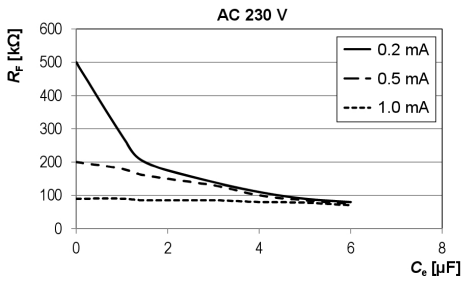
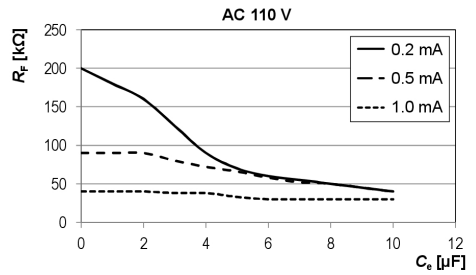
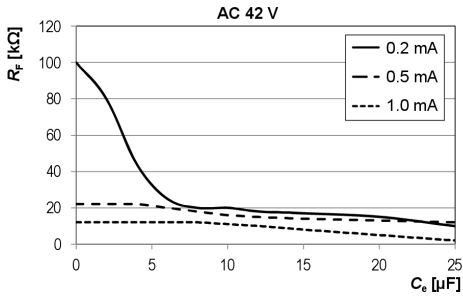

4.4.5 Response characteristics for control circuits in DC systems

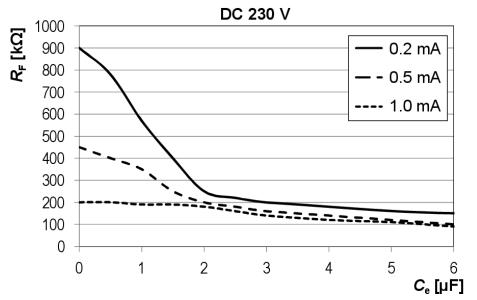
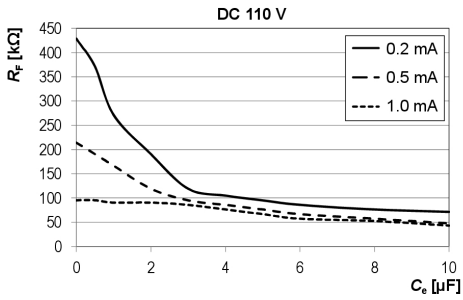
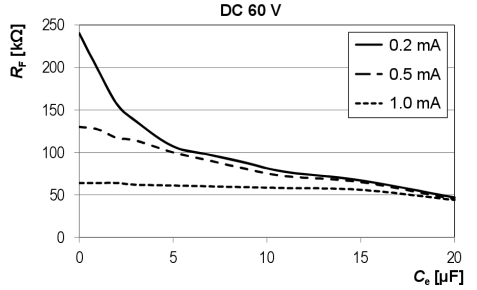
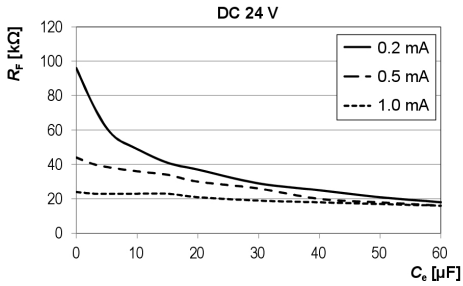

5 Connecting the locating current injector



ADVICE

Hazard due to excessively high locating voltage

The operation of the PGH18... and possibly the power supply unit with an incorrect supply voltage can cause irreparable damage to the devices.

- Check the information on the nameplate to ensure the devices to be connected are suitable for the supplying system.



Before commissioning, check that all system components are correctly connected.

5.1 Disconnecting insulation monitoring device

During insulation fault location using the EDS309... any insulation monitoring device with an internal resistance $R_i < 120 \text{ k}\Omega$ must be disconnected from the system on all poles. Shutting down the supply voltage to the insulation monitoring device is not sufficient.

Devices with $R_i \geq 120 \text{ k}\Omega$ do not need to be disconnected. The influence is negligible. However, the PGH18... influences the measurement of the insulation monitoring device.

5.2 Locating current injector in a de-energized IT system

For insulation fault location in de-energized systems using the EDS3096PG, the integrated voltage source G in the PGH186 supplies a locating voltage.

The locating voltage DC 50 V is provided by the PGH186 at the socket L1(+). Make sure that this socket is coupled to the system to be monitored during insulation fault location, only then will the integrated voltage source in the PGH186 be effective.



The active conductors in the system to be checked must be coupled together via loads or the electrically isolated power supply.

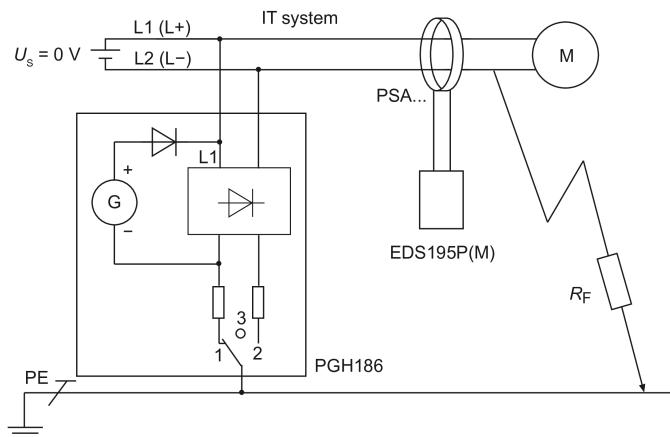

5.3 Connection to a live IT system



DANGER

Risk of electric shock

Touching live, uninsulated wires can cause death or serious injury.

- Avoid any physical contact with live wires.
- Follow the rules for working on electrical systems.



DANGER

Risk of electric shock

If the PGH18... is connected to a live system without a PE conductor, life-threatening system voltage will be present at terminal \perp .

- Only connect the PGH18... to a live system with a PE protective conductor at terminal \perp .

Connect the locating current injector PGH18... as follows:

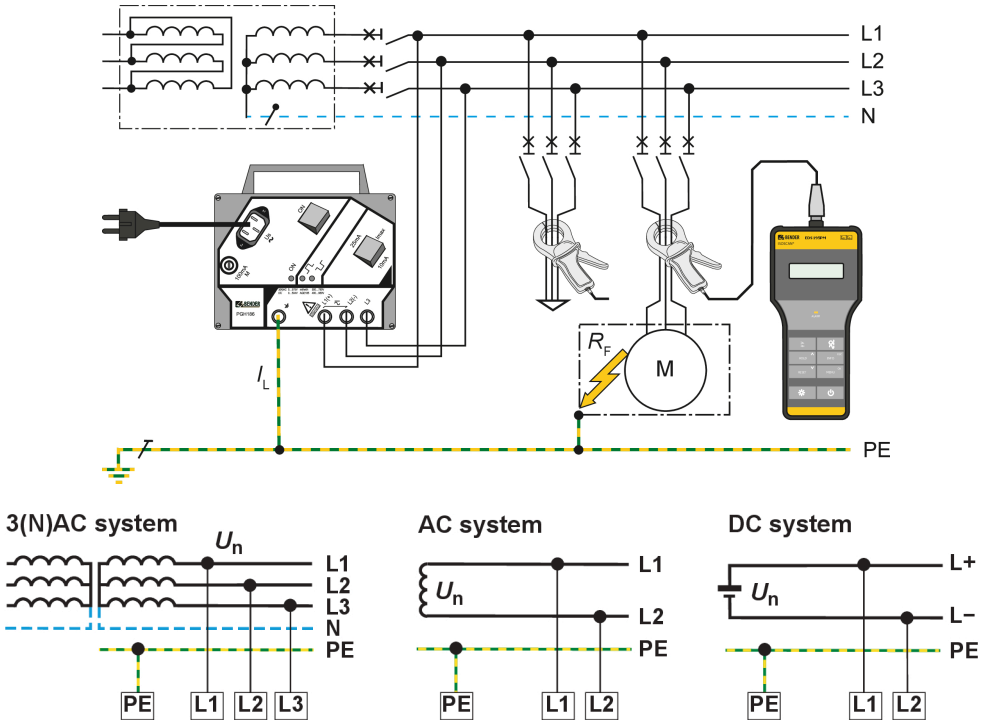

5.4 Connection to a PV system



DANGER

Risk of electric shock

Touching live, uninsulated wires can cause death or serious injury.

- *Avoid any physical contact with live wires.*
- *Follow the rules for working on electrical systems.*



DANGER

Risk of electric shock

If the PGH18... is connected to a live system without a PE conductor, life-threatening system voltage will be present at terminal \perp .

- *Only connect the PGH18... to a live system with a PE protective conductor at terminal \perp .*



CAUTION

Risk of short circuit

When the EDS3090PV is connected with test leads without integrated fuses a short circuit may occur due to incorrect wiring.

- *Connect the EDS3090PV with the accompanying test lead with integrated fuses.*

Connect the locating current injector PGH186 as follows:

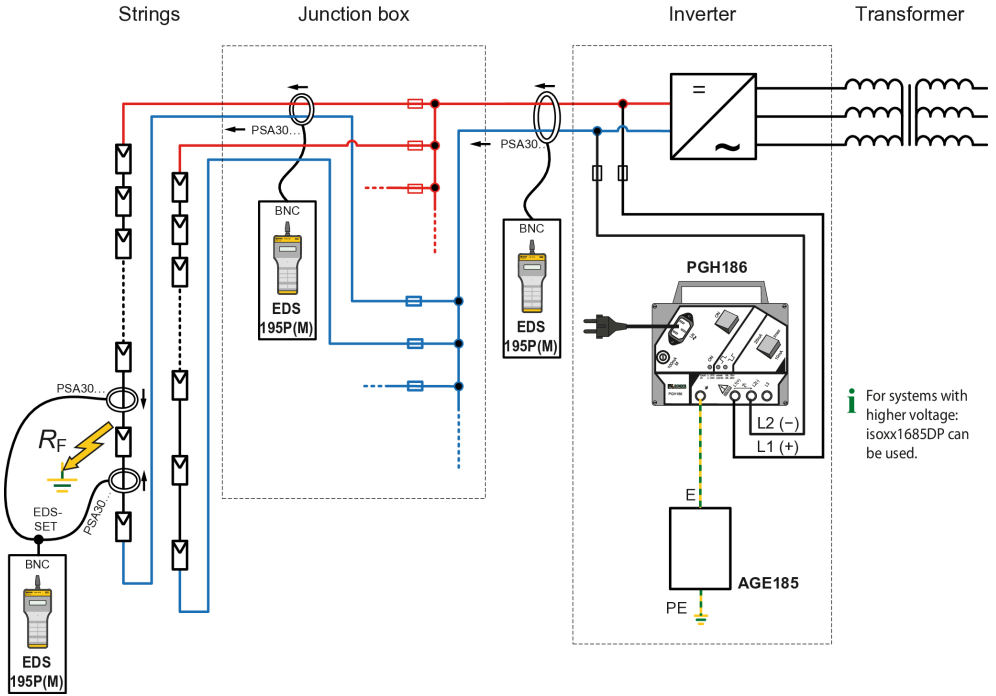

- PGH186 Locating current injector
- AGE185 Coupling device
- EDS3096PV Equipment for insulation fault location
- EDS195P(M) Insulation fault locator
- PSA30... Measuring clamp (locating current sensor)
- EDS-SET BNC T-connector and 2 BNC cables for fault localisation in diode-decoupled systems

For insulation fault location within the junction box, it is essential that the +/– cables of a string are arranged in a way that the measuring clamp PSA30... can be put around the cables.

Insulation faults in the strings can be localised by means of two measuring clamps connected in parallel and an EDS-SET. For this purpose, place the measuring clamps on both sides of the module supply conductors in the direction indicated by the arrows.

6 Operation

6.1 Short description of insulation fault location (EDS mode)



DANGER

Risk of electric shock

Touching live, uninsulated wires can cause death or serious injury.

- *Avoid any physical contact with live wires.*
- *Follow the rules for working on electrical systems.*

Commissioning the PGH18... for locating current injection

1. Connect the PGH18... to PE in the system to be checked, see "Connection to a live IT system", page 27.
2. Connect the PGH18... to the active conductors.
3. Connect device to U_S and switch on.

If the locating current I_L is to be supplied by an IRDH575, iso685-x-P or isoxx1685xP, select the EDS-Setup menu item **Use Portable EDS - on**.

Insulation fault location using EDS195P(M)



During commissioning, there must be no conductors in the measuring clamp and the measuring clamp must be stationary.

1. Switch on EDS195P(M) without current transformer using the \cup button.
2. Wait for the end of the self test and the message **No CT connected**.
3. Set required current transformer type using the RT button.
4. Connect selected current transformer and wait for end of the self-test.
5. Fit measuring clamp to PE conductor between PGH18... (IRDH575, iso685-x-P or isoxx1685xP) and, for example, PE rail to demonstrate the necessary locating current I_L .
6. Place measuring clamp around the associated active conductors for the related outgoing circuit.
NOTICE! Do not include PE in the clamp.
7. Read measured value and evaluate.
 - If the response value set has been exceeded, the **ALARM** LED flashes.

6.2 Detailed description of insulation fault location

For information on using the EDS309...

- without a permanently installed EDS system, see "Insulation fault location in a system without a permanently installed EDS system", page 41
- in addition to a permanently installed EDS system, see "Insulation fault location in a system with a permanently installed EDS system", page 43
- in diode-decoupled DC systems, see "Usage of the EDS195PM as a residual current meter", page 48

6.3 Description of a residual current measurement

The EDS195P(M) allows residual current measurements up to 10 A, see "Usage of the EDS195PM as a residual current meter", page 48.

6.4 Display and operating elements of the PGH18...

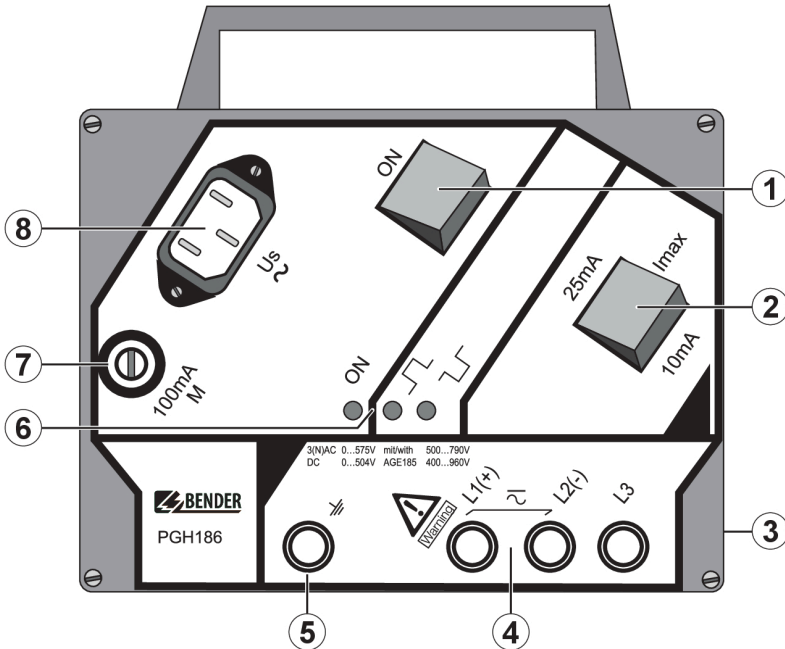

1	ON/OFF switch, switch on or off locating current
2	Changeover switch for maximum locating current values: 25mA / 10mA or 2.5mA / 1mA
3	Rear: Magnetic strip for attachment to metal items (e.g. switch cabinet)
4	3 sockets for coupling to system
5	Socket for PE connection
6	Indicator LEDs <ul style="list-style-type: none"> • ON: Operation LED • : positive locating current cycle • : negative locating current cycle
7	Fine-wire fuse 100 mA
8	Connector for supply voltage

6.5 Display and operating elements of the EDS195P(M)



1	BNC connection for measuring clamp
2	Measuring signal output for connecting to an oscilloscope (EDS195PM only)
3	Micro USB connection for charging the device's rechargeable batteries
4	LC display, illuminated, 3 lines of 16 characters
5	ALARM LED <ul style="list-style-type: none"> flashes if the response value is exceeded lights up continuously when the fault is cleared and the fault memory is activated
6	Control buttons

Control buttons

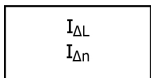

Select the operating mode:

I_{ΔL} Insulation fault location in IT systems (EDS mode)

I_{Δn} Residual current measurement in TN-S systems (RCM mode)

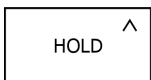

HOLD

Save the measured value.

^

Move up in the menu, increase parameter values.



RESET

Delete fault memory.

v

Move down in the menu, reduce parameter values.

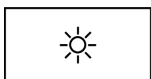

Switch display lighting on/off.



Select current transformer:

Display	Device	suitable for
PSA30xx	PSA30... / PSA3165	$I_{Lmax} = 50 \text{ mA}$
CTAF		$I_{Lmax} = 50 \text{ mA}$ $I_{Lmin} = 25 \text{ mA}$
W/WR/WS	W... / WR... / WS...	$I_{Lmax} = 50 \text{ mA}$
PSA33xx	PSA33...	$I_{Lmax} = 5 \text{ mA}$
W/WS-8000	W....-8000 / WS....-8000	$I_{Lmax} = 5 \text{ mA}$
WF	WF...	$I_{\Delta n}$



INFO Display device info:

- device type, date, time, manufacturer
- software version
- Actual response values $I_{\Delta L}$ and $I_{\Delta n}$
- status word (setup status)

ESC Leave a menu function without changing parameters.



MENU Open the menu.
OK Accept modified parameter values or selected menu items.



Switch device on/off.

6.6 Operating the EDS195P(M)

6.6.1 Switching on and off the device

Switching on

- Switch on the device without current transformer using button.
- ✓ The self-test starts. Then **No CT connected** appears.

Switching off

- Press button for around 2 s.

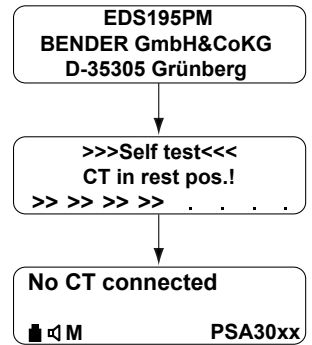

Figure 6-1: Start sequence of the EDS195P(M)

6.6.2 Changing the measuring clamp

EDS195P(M) switched off:

1. Disconnect clamp no longer required.
2. Switch on EDS195P(M).
3. Wait for **No CT connected** message.
4. Set required clamp type.
5. Connect related clamp.
6. Wait for end of self-test.

EDS195P(M) in operation:

1. Disconnect clamp from the device.
2. Wait for **No CT connected** message.
3. Set required clamp type.
4. Connect related clamp.
5. Wait for end of self-test.

6.6.3 Switch on display lighting

Press  button to switch display lighting on or off.

6.6.4 Change between insulation fault location $I_{\Delta L}$ and residual current measurement $I_{\Delta n}$

Press $I_{\Delta L} | I_{\Delta n}$ button to select measuring function:

- $I_{\Delta n}$ for residual current measurement preferably in TN/TT systems
- $I_{\Delta L}$ for insulation fault location in IT systems

Avoid changing the measuring function during insulation fault location.

6.6.5 Quickly check the response values for $I_{\Delta L}$ and $I_{\Delta n}$

Press **INFO** button 3× to display the actual response values.

6.6.6 Checking Info menu

The following information appears on the display in succession on pressing the **INFO** button:

- Device name, time, date and manufacturer
- Software version with date
- Actual response values $I_{\Delta L}$ and $I_{\Delta n}$
- Status word, coded, see "Status word", page 64

6.6.7 Meaning of the display elements

The elements shown refer to EDS mode ($I_{\Delta L}$) for insulation fault location.

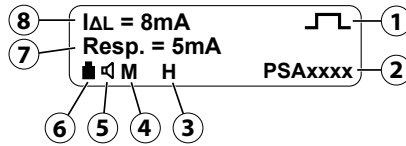

1	Locating current pulse: = positive pulse --- = pause or no measurement possible when permanently displayed = negative pulse ► 29 = timer (29...0) shows the duration of a measurement of an outgoing circuit
2	Selected transformer type (see "Display and operating elements of the EDS195P(M)", page 32)
3	H = Hold function is activated; measured value indication "frozen"
4	M = Fault memory is activated
5	Loudspeaker symbol visible: alarms are also output audibly
6	Charge state of the rechargeable battery in the steps 0 %, 33 %, 66 %, 100 %
7	Resp. = Response value of $I_{\Delta L}$
8	$I_{\Delta L}$ = actual locating current measured

6.7 Standard displays on the EDS195P(M)

6.7.1 EDS measurement ($I_{\Delta L}$)

Standard display if there is no cable to be measured in the clamp

The device is in EDS mode ($I_{\Delta L}$).

A measured locating current $I_{\Delta L}$ is not indicated, as there is no conductor in the measuring clamp. The display shows the timer count (29...0).

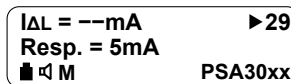

Standard display for EDS measurement ($I_{\Delta L}$) with cable in the clamp

The display is indicating a measured fault current $I_{\Delta L}$ of 3 mA. A measurement in progress is indicated by the change in the polarity of the measuring pulse () with a pause (---) in between.



PSA30xx



PSA30xx

Note that only half the magnitude of the locating current I_L generated by the PGH18... in AC systems is indicated by EDS195P(M). The half-wave rectification used in the PGH18... reduces the value indicated in AC systems to 50 %, in 3AC systems to 67 %.

Standard display for measuring faults or pauses between changes in polarity of the measuring pulse

When no measurement is possible due to low frequency residual currents or because the measuring clamp is not being held still, the display permanently indicates a pause (---) at the top right corner. During the evaluation of the measurement the display indicates a pause (---) for a short time only.

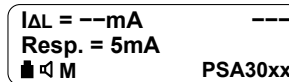

PSA30xx

6.7.2 RCM measurement ($I_{\Delta n}$)

Standard display for RCM measurement ($I_{\Delta n}$) with cable in the clamp

The display is indicating the measured residual current $I_{\Delta n}$ of 16 mA.

The residual current response value set is 100 mA.

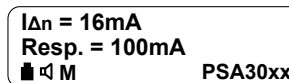

PSA30xx

The display below appears when this menu item is activated: **2.Settings > 7.Harmonics: on**. This setting can only be used for 50 Hz or 60 Hz systems.

For the 1st harmonic (fundamental) the display is indicating a measured current of 10 mA as well as a total harmonic distortion THD of 39 %.

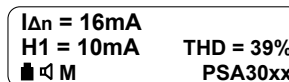

THD = 39%

PSA30xx

6.8 Alarms during EDS measurement or RCM measurement

If one of the response values $I_{\Delta L}$ or $I_{\Delta n}$ is exceeded, the **ALARM** LED flashes. If the fault memory **M** is activated, the **ALARM** LED remains lit after the removal of the fault. The stored alarm is cleared using the **RESET** button.

$I_{\Delta L} = 8\text{mA}$ 

Resp. = 5mA

 M PSA30xx

$I_{\Delta n} = 1.6\text{mA}$

Resp. = 100mA

 M PSA30xx

 Alarm during insulation fault location (EDS):
ALARM LED flashes

 Alarm during a residual current measurement (RCM):
ALARM LED flashes

6.9 Indication of device and measuring errors

The following table explains the error messages that may occur.

Self test error

PRESS ->RESET

 M PSA30xx

Can only occur after the end of the self-test:

- Incorrect current transformer type is set.
- During the self-test,
 - the clamp was not stationary or
 - a residual current was flowing through the clamp
 - the PGH locating current was flowing through the clamp.
- The EDS195P(M) hardware is faulty.

Press the **RESET** button to restart a self test.

No CT connected

 M PSA30xx

No measuring clamp or no measuring current transformer on the measuring input or incorrect transformer type connected.

Measures

- Connect correct measuring clamp or correct measuring current transformer.

$I_{\Delta L} = \text{---mA}$ ---

Resp. = 5mA

 M PSA30xx

A permanent display of --- indicates that no measurement is possible.

Measures

- Hold the measuring clamp still.
- Avoid low frequency residual currents.

Error $I_{\Delta L}$

 M PSA30xx

A malfunction has occurred during insulation fault location.

Possible causes

- The measuring clamp was not held still.
- There is a low frequency residual current flowing through the measuring clamp that is interfering with the EDS measurement.
- There is a magnetic field around the measuring clamp that is interfering with the EDS measurement .
- The EDS195P(M) hardware is faulty.



If the EDS195P(M) can no longer detect the locating current due to system interference and an existing alarm is therefore cleared, an insulation fault will be detected again at the end of the interference.

6.10 Factory settings EDS195P(M)

Object	Factory setting	Can be set via
Operating mode	$I_{\Delta L}$ (EDS mode = insulation fault location)	button
Current transformer	Measuring clamp PSA3052 (for EDS3090 and 3096) Measuring clamp PSA3352 (for EDS3091)	button
Illumination	off	button
Fault memory	on	menu
Buzzer	on	menu
Response value $I_{\Delta L}$ with PSA30...	5 mA	menu
Response value $I_{\Delta L}$ with PSA33...	0.5 mA	menu
Response value $I_{\Delta n}$	100 mA	menu
System frequency $I_{\Delta n}$	50 Hz	menu
Measurement of harmonics $I_{\Delta n}$	off	menu
User interface language	English	menu
Time	CET	menu

6.11 Menu structure

1. Exit		
2. Settings	1. Exit	
	2. I _{ΔL} ALM: 0.2...10 mA	
	3. I _{Δn} ALM: 10 mA...10 A	
	4. Memory: on/off	
	5. Buzzer: on/off	
	6. Frequ.: 50/60Hz/up to 1kHz	
	7. Harmonics: on/off	
3. System	1. Exit	
	2. Language	1. Exit
		2. German
		3. English
		4. French
		5. Russian
	3. Clock	1. Exit
		2. Format: D.M.Y
		3. Date
		4. Time
4. Contrast: 0...15		
4. Harmonics	1. Exit	
	2. H1 < 10 mA	
	3. H2 < 10 mA	
	...	
	9. H8 < 10 mA	
5. I _{ΔL} alarms	1. Exit	
	2. Entries	
	3. Delete	1. Exit
2. Delete Data		
6. I _{Δn} logger	1. Exit	
	2. Entries	
	3. Change: 10...100 %	
	4. Overwrite: yes/no	
	5. Delete	1. Exit
2. Delete Data		
7. Service		

6.11.1 Navigating in the menu

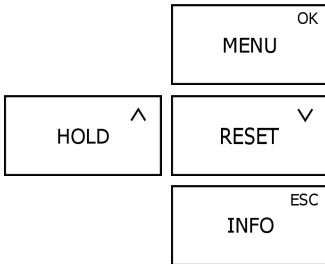

MENU: Open the menu

OK: Select a menu item or accept changes

^ / v:

- Navigate up or down in the menu
- Increase or reduce values

ESC:

- Return from the last menu item selected
- Discard changes

6.11.2 Menu item 2. Settings

Set parameters for the insulation fault location and the residual current measurement:

2. $I_{\#L}$ ALM: 0.2...10 mA

Set the response value for the locating current $I_{\Delta L}$ measured with the measuring clamp between 0.2...10 mA.

This value range is equally suitable for control circuits (0.2...1 mA) and main circuits (2...10 mA).

When using the locating current injector

- control circuits: $I_{Lmax} = 5$ mA
- main circuits: $I_{Lmax} = 50$ mA

3. $I_{\#n}$ ALM: 10 mA...10 A

Set the response value for the residual current $I_{\Delta n}$ measured with the measuring clamp: 10 mA ... 10 A

4. **Memory: on/off**

Activate or deactivate the fault memory

5. **Buzzer: on/off**

Activate or deactivate audible signalling of alarms

6. **Frequ.: 50/60Hz/up to 1kHz**

Set the frequency of the system monitored

7. **Harmonics: on/off**

Enable the indication of the harmonics to display the current for the harmonic with the greatest amplitude in the standard display. All harmonics from H1 to H8 can be checked using menu item **4. Harmonics**, see also "Menu item 4. Harmonics", page 40. With harmonics activated only system frequencies of 50 Hz and 60 Hz can be selected.



In delivery condition, alarms are signalled by the Alarm LED and the buzzer.

6.11.3 Menu item 3. System

Select the language for the user interface, set date and time, and adjust display contrast.

6.11.4 Menu item 4. Harmonics

Display harmonics from H1 to H8.

To display the harmonic with the greatest amplitude in the standard display activate this menu item:

2. Settings > 7. Harmonics: on/off > on

6.11.5 Menu item 5. $I_{\Delta L}$ alarms

Check the alarms recorded during insulation fault location.

The data records are numbered and contain the following information

- start of the alarm
- end of the alarm
- minimum locating current $I_{\Delta L}$ measured
- maximum locating current $I_{\Delta L}$ measured

A maximum of 300 data records is saved. The data records can be deleted via the menu.

6.11.6 Menu item 6. $I_{\Delta n}$ logger

Check the measured values of a residual current measurement.

2. Entries

The data records are numbered and contain the following information

- start time of the measurement and the change in the monitored residual current
- measured residual current $I_{\Delta n}$

3. Change: 10...100 %

Percentage change from which logging becomes active

4. Overwrite: yes/no

Overwrite oldest data record

A maximum of 300 data records are saved. The data records can be deleted via the menu.

6.12 Practical usage



ADVICE

Incorrect triggering due to wrong measuring values

The power supply unit influences the measuring accuracy of EDS195PM.

- *Never connect the power supply unit during measurements.*

6.12.1 Insulation fault location in a system without a permanently installed EDS system



DANGER







Risk of electric shock

Touching live, uninsulated wires can cause death or serious injury.

- *Avoid any physical contact with live wires.*
- *Follow the rules for working on electrical systems.*

The EDS309... is primarily used as a portable insulation fault location system in unearthed IT systems. Once all the instructions in chapter "To consider before use", page 17 have been followed, insulation fault location can be started:

1. Check whether the system voltage is within the permissible limits.
The permissible voltages are stated in the user interface on the PGH18...
2. Connect the locating current injector PGH18... close to the feed, see "Connection to a live IT system", page 27. During this process follow the general guidelines for working with electrically live systems!

- First connect the PE socket on the PGH18... to the system's PE using the green-yellow wire.
 - Then connect the PGH18... to the system to be checked using the connection wires provided.
 - Three-phase system: Connect sockets L1, L2 and L3 to the system
 - Single-phase AC or DC: Connect sockets L1 and L2 to the system
3. Connect the PGH18... to a suitable power supply using the power cable supplied (see nameplate).
 4. If there is an insulation monitoring device with an internal resistance < 120 kΩ in the IT system to be checked, disconnect it from the system to be checked on all poles. It is not sufficient to switch off the power supply to the insulation monitoring device.
 5. Set the maximum locating current using the **I_{max}** switch on the PGH18.... Follow the instructions in chapter "Reduced locating current", page 19.
 6. Switch on the PGH18.... The **ON** LED illuminates and the two  and  LEDs flash alternately in synchronism with the test cycle. If there is no activity indicated on the LEDs, check the supply voltage and the fine-wire fuse that can be accessed from the front panel.
 7. Switch on the EDS195PM without a current transformer connected by pressing the  button. The device performs a self-test and displays **No CT connected**.
 8. Select the type of measuring clamp or measuring current transformer to be connected using the  button. The device performs another self-test and displays **No CT connected**.
 9. Connect the pre-selected measuring clamp or measuring current transformer to the EDS195PM. The device performs another self-test and is then in the EDS mode. **I_{#L}** appears in the first line of the display.
 10. Note on handling the measuring clamp:
 - Do not bring measuring clamp into contact with system voltages above the rated insulation voltage (see nameplate on the measuring clamp with information on measuring category, e.g. CAT III)
 - Always keep contact surfaces on measuring clamp's iron core clean.
 - Do not use measuring clamp in the immediate vicinity of devices that produce magnetic fields such as transformers or chokes and also not near adjacent conductors carrying high currents.
 - Never disconnect measuring clamp from the EDS195PM while it is placed around electrically live conductors. Otherwise the measuring clamp may be irreparably damaged!
 - Aim for the best possible symmetry of the conductors in the measuring clamp. Otherwise the measuring clamp may go into saturation due to an excessively high load current and cause an alarm **I_{#n} > 10 A**.
 - Keep the measuring clamp **still** during the measurement!
 - During the measurement do not apply any pressure to the clamp limb.
 11. Cover the green and yellow lead between PHG18... and earth with the measuring clamp. A measurement process should take no more than 30 seconds. When the EDS195PM is ready to take a measurement, the countdown (29...0) at the top right corner of the display starts. If the time has expired and no error has been found, the countdown starts again. During a measurement, the EDS195PM shows recognized test current signals with pauses in between: i.e. , ---, .
In the case of a measurement fault, the display permanently indicates ---.
There are 3 reasons for this:
 - The insulation fault resistance is too high and cannot be measured by the EDS195PM.
 - The measuring clamp is not held still.
 - Low-frequency residual currents or magnetic fields in the environment are superimposed on the test current pulse.

12. Start the insulation fault location from the main distribution area of the IT system. Place the measuring clamp around all system conductors, but **not** the PE conductor. During each measurement wait one test cycle (approx. 30 s). A flashing alarm LED on the EDS195PM signals an insulation fault after the measuring clamp (from the point of view of the locating current injector). It is recommended to have the buzzer activated during the search.
13. Measure along the cable using the EDS195PM until the fault is found.
During this process move into sub-distribution systems using a star-shaped approach. The location of the fault is found when the locating current in the measuring clamp exceeds the response value of the EDS195PM.

Possible error messages

- **Self test error**

- Incorrect current transformer type set
- EDS195PM hardware faulty
- Clamp moved while the indication >>>**Self test**<<< was displayed
- An interfering residual current is flowing through the clamp
- There is a PGH locating pulse acting on the clamp

- **No CT connected**

Measuring clamp or measuring current transformer not connected or faulty.

- **Error $I_{\#L}$** (can only be indicated while a measurement is in progress):

- Low frequency interference, measurement not possible
- EDS195PM hardware faulty

- **$I_{\#n} > 10\text{ A} / I_{\#n} > 1\text{ A}$**

There is a residual current $> 10\text{ A}$ or $> 1\text{ A}$ flowing through the measuring clamp. In this case it is not possible to locate the insulation fault on the related outgoing circuit. Residual currents of this magnitude in an IT system can be caused by large system leakage capacitances or multiple insulation faults. It is therefore possible that there is an insulation fault on this outgoing circuit even with this alarm message.



At operating currents $< 10\text{ A}$ a measurement can also be made by placing the clamp around only one conductor. At currents $> 10\text{ A}$ it may no longer be possible to open the measuring clamp. This risk is particularly apparent in DC systems.

- *Do not use force to open the measuring clamp. Risk of destruction!*
- *Shut down the related system, then open the measuring clamp without force.*

6.12.2 Insulation fault location in a system with a permanently installed EDS system

The EDS195PM can also be used in a permanently installed EDS system (EDS460/490 or EDS461/491). In a large, complex IT system the main outgoing circuits are often monitored by the permanently installed EDS system. Once the main outgoing circuit affected by an insulation fault is detected, the search is continued from there using the portable EDS195PM. During this process the EDS195PM uses the locating current pulse from the permanently installed EDS system (IRDH575, iso685-x-P or isoxx1685xP or PGH47...). The PGH18... is not required for this application.

The PGH18... is not included in the items supplied with the EDS3090 and EDS3091. Insulation fault location is therefore only possible in electrically live IT systems. Also follow the operating instructions for the permanently installed EDS system.

**DANGER****Risk of electric shock**

Touching live, uninsulated wires can cause death or serious injury.

- Avoid any physical contact with live wires.
- Follow the rules for working on electrical systems.

Example: The insulation monitoring device has signalled an insulation fault below its response value and started the permanently installed EDS system. The main outgoing circuit affected by the insulation fault has been detected.

Proceed as follows for the further insulation fault location:

1. Set the mode of the EDS system to continuous insulation fault location:
 - IRDH575: On the **EDS Setup** menu set the **EDS on** mode.
 - iso685-D-P, isoxx1685xP:
 1. Open the menu **EDS > 1 General > 3 Using a portable EDS** and select **on**.
 2. Press the **EDS** button to start the permanent insulation fault location.
 - PGH471: Press **START/STOP** button.
2. Switch on the EDS195PM without a current transformer connected by pressing the \cup button. The device performs a self-test and displays **No CT connected**.
3. Select the type of measuring clamp or measuring current transformer to be connected using the \mathcal{R} button. The device performs another self-test and displays **No CT connected**.
4. Connect the pre-selected measuring clamp or measuring current transformer to the EDS195PM. The device performs another self-test and is then in the EDS mode. $I_{\#L}$ appears in the first line of the display.
5. Note on handling the measuring clamp:
 - Do not bring measuring clamp into contact with system voltages above the rated insulation voltage (see nameplate on the measuring clamp with information on measuring category, e.g. CAT III)
 - Always keep contact surfaces on measuring clamp's iron core clean.
 - Do not use measuring clamp in the immediate vicinity of devices that produce magnetic fields such as transformers or chokes and also not near adjacent conductors carrying high currents.
 - Never disconnect measuring clamp from the EDS195PM while it is placed around electrically live conductors. Otherwise the measuring clamp may be irreparably damaged!
 - Aim for the best possible symmetry of the conductors in the measuring clamp. Otherwise the measuring clamp may go into saturation due to an excessively high load current and cause an alarm $I_{\#n} > 10 \text{ A}$.
 - Keep the measuring clamp **still** during the measurement!
 - During the measurement do not apply any pressure to the clamp limb.
6. Place the measuring clamp around the green-yellow wire between the IRDH575, iso685-x-P or isoxx1685xP or PGH47... and earth. If the EDS195PM does not react, the insulation fault has an excessively high impedance and cannot be detected. Locating current pulses detected are indicated using the \llcorner symbol.

7. Start the insulation fault location from the main distribution area of the IT system. Place the measuring clamp around all system conductors, but **not** the PE conductor. During each measurement wait one test cycle (approx. 30 s). A flashing alarm LED on the EDS195PM signals an insulation fault after the measuring clamp (from the point of view of the locating current injector). It is recommended to have the buzzer activated during the search.
8. Measure along the cable using the EDS195PM until the fault is found.
During this process move into sub-distribution systems using a star-shaped approach. The location of the fault is found when the locating current in the measuring clamp exceeds the response value of the EDS195PM.

Possible error messages

- **Self test error**

- Incorrect current transformer type set
- EDS195PM hardware faulty
- Clamp moved while the indication >>>**Self test**<<< was displayed
- An interfering residual current is flowing through the clamp
- There is a PGH locating pulse acting on the clamp

- **No CT connected**

Measuring clamp or measuring current transformer not connected or faulty.

- **Error $I_{\#L}$** (can only be indicated while a measurement is in progress):

- Low frequency interference, measurement not possible
- EDS195PM hardware faulty

- **$I_{\#n} > 10 \text{ A} / I_{\#n} > 1 \text{ A}$**

There is a residual current $> 10 \text{ A}$ or $> 1 \text{ A}$ flowing through the measuring clamp. In this case it is not possible to locate the insulation fault on the related outgoing circuit. Residual currents of this magnitude in an IT system can be caused by large system leakage capacitances or multiple insulation faults. It is therefore possible that there is an insulation fault on this outgoing circuit even with this alarm message.



At operating currents $< 10 \text{ A}$ a measurement can also be made by placing the clamp around only one conductor. At currents $> 10 \text{ A}$ it may no longer be possible to open the measuring clamp. This risk is particularly apparent in DC systems.

- *Do not use force to open the measuring clamp. Risk of destruction!*
- *Shut down the related system, then open the measuring clamp without force.*

6.12.3 Insulation fault location in diode-decoupled DC systems

In diode-decoupled DC systems equalising currents occur in and between the decoupled circuits. The direction and magnitude of these equalising currents is dependent on voltages in the system, the characteristics of the decoupling diodes and the characteristics of the loads.

On the usage of the insulation fault location system EDS309... in such systems these equalising currents make themselves apparent and can degrade the accuracy of the measurement. For this reason we recommend the usage of the EDS309... in diode-decoupled systems as shown in the sketch Fig. 6-2.

**DANGER****Risk of electric shock**

Touching live, uninsulated wires can cause death or serious injury.





- Avoid any physical contact with live wires.
- Follow the rules for working on electrical systems.

During this process please note:

- Always use two measuring clamps of the same type.
NOTICE: This clamp type must also be set on the EDS195PM.
- For this purpose use the EDS195PM set (see "Ordering details", page 65).
- Take into account the maximum length of the coax cable of 10 m per measuring clamp.
- The usage of two measuring clamps results in a sensitivity loss of around 10 %.
- Use both measuring clamps so that the direction of the energy flow corresponds to the arrow printed on the clamp.

Example: The central insulation monitoring device in a DC system without permanently installed insulation fault location system (EDS) has signalled an insulation fault that is below the insulation value that can be located using the EDS system. Once all the instructions from chapter "To consider before use", page 17 have been followed, fault location in a modified form can be started. Proceed as follows during this process.

Proceed as follows:

1. Read the actual insulation resistance on the insulation monitoring device. If the value read for the insulation resistance is lower than the maximum insulation fault that can be located by the EDS system, two appropriate identical measuring clamps (e.g. 2 × PSA3020 or 2 × PSA3052) are required for the insulation fault location.
2. Switch on the EDS195PM without a current transformer by pressing the  button. The device undertakes a self-test and outputs the error message **No CT connected**.
3. Select the type of measuring clamp(s) to be connected using the  button. The device undertakes a further self-test and outputs the error message **No CT connected** because a current transformer is not connected.
4. Then connect the pre-selected measuring clamp(s) to the EDS195PM. The device undertakes a further self-test and is then in the EDS mode. **I_{#L}** appears in the first line of the display.
5. Connect the PGH18... to the locating current injection points as shown in the following connection diagram.
6. Start the EDS system:
Switch on the PGH18.... The **ON** LED illuminates and the two and LEDs  and  flash in synchronism with the test cycle. If there is no activity indicated on the LEDs, check the supply voltage and the fine-wire fuse fitted in the PGH18...
7. Locate insulation fault in the system:
 - Place a measuring clamp around each of the supply cables to the redundantly supplied loads. During this process ensure that the clamp is placed around all related load supply cables for a diode-decoupled load.
 - Pay attention to identical directions of flow on the two measuring clamps (see connection diagram). For this purpose the measuring clamps are marked with an arrow.
8. Place the two measuring clamps successively and systematically around all parallel outgoing cables for loads. Outgoing cables for loads with an insulation fault are indicated by the flashing alarm LED on the EDS195PM. The alarm messages are output in the same way as for an application with a single measuring clamp. For possible error messages see "Possible error messagesPossible error messages", page 43.

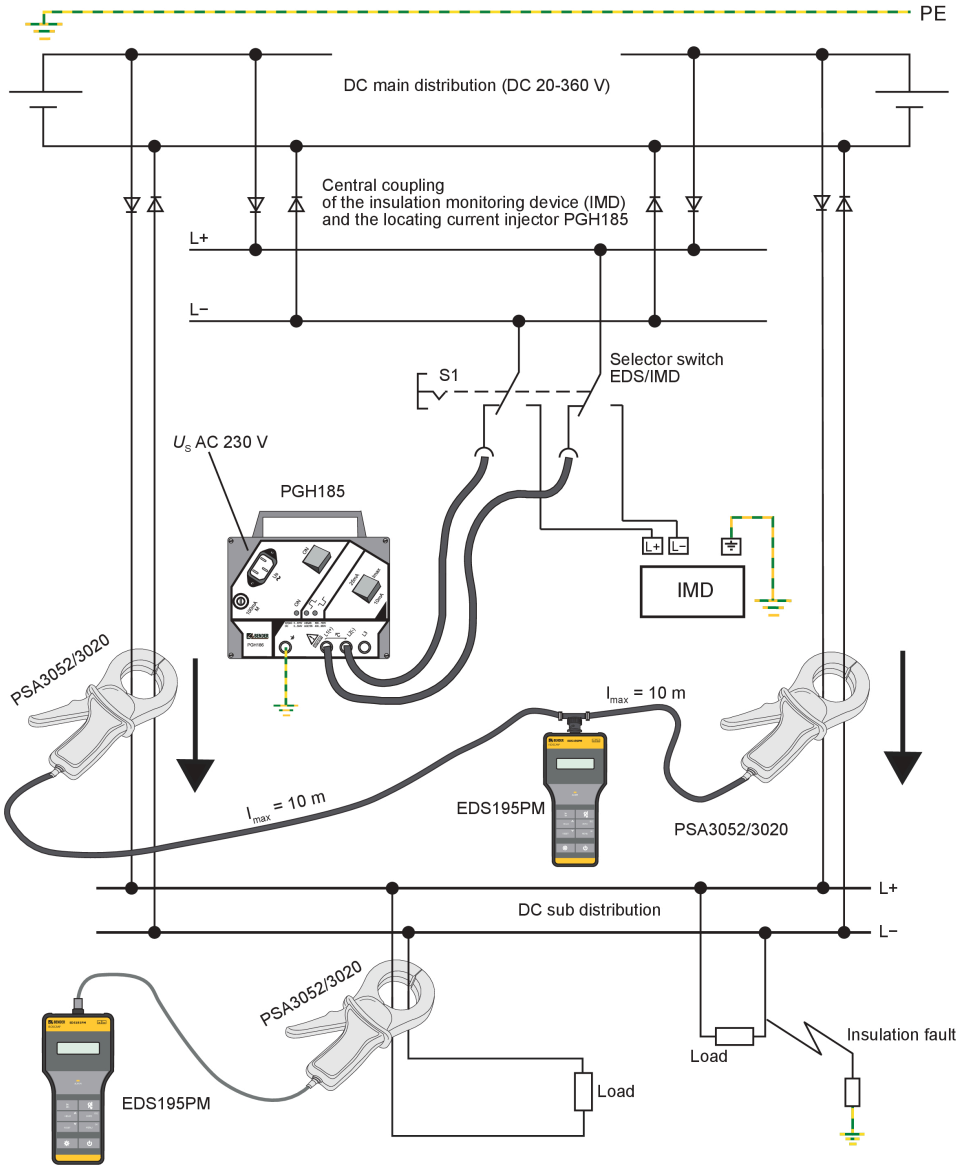

Figure 6-2: Insulation fault location in diode-decoupled DC systems (connection diagram)

6.12.4 Usage of the EDS195PM as a residual current meter

The EDS195PM can be used as a residual current meter up to AC 10 A in TN and TT systems. Residual current measurement is only possible in electrically live systems. The locating current injector PGH18... is not required for this application.

1. Check whether the system voltage is within the permissible limits.
2. Switch on the EDS195PM without a current transformer connected by pressing the \cup button.
The device performs a self-test and displays **No CT connected**.
3. Select the type of measuring clamp or measuring current transformer to be connected using the \mathcal{R} button.
The device performs another self-test and displays **No CT connected**.
4. Connect the pre-selected measuring clamp or measuring current transformer to the EDS195PM.
The device performs another self-test and is then in the EDS mode. $I_{\#L}$ appears in the first line of the display.
5. Make the following settings:
 - Select RCM mode ($I_{\Delta n}$) using the $I_{\#L} | I_{\#n}$ button.
 - Set residual current response value using the menu path
2. Settings > 3. I Δ n ALM:
6. Note on handling measuring clamps:
 - Do not bring measuring clamp into contact with system voltages above the nominal insulation voltage. (See nameplate on the measuring clamp)
 - During the measurement place the clamp around all system conductors, **but not PE**. Do not place the clamp around screened conductors.
 - Always keep contact surfaces on measuring clamp's iron core clean.
 - Do not use measuring clamp in the immediate vicinity of devices that produce magnetic fields such as transformers or chokes and also not near adjacent conductors carrying high currents.
 - Never disconnect measuring clamp from the EDS195PM while it is placed around electrically live conductors. Otherwise the measuring clamp may be irreparably damaged!
 - Aim for the best possible symmetry of the conductors in the measuring clamp. Otherwise the measuring clamp may go into saturation due to an excessively high load current and cause an alarm $I_{\#n} > 10 \text{ A}$.
 - Keep the measuring clamp still or let go of it during the measurement.
 - During the measurement do not apply any pressure to the clamp limb.
7. Start the measurement from the main distribution area of the system. Now measure along the cable using the EDS195PM until the insulation fault is found. During this process move into sub-distribution systems using a star-shaped approach.
8. EDS195PM indicates the residual current at each measuring point. If the residual current is greater than the response value set, the **ALARM** LED illuminates and the measured value is displayed. If the buzzer is activated, there is also an audible signal.
9. For long-term measurements at a point in the system, the fault memory is to be activated (**MENU > 2. Settings > 4. Memory**). In this way it is also possible to find intermittent residual currents provided they are above the response value set. The highest residual current measured is stored.

Possible error messages

• Self test error

- Incorrect current transformer type set
- EDS195PM hardware faulty
- Clamp moved while the indication >>>Self test<<< was displayed
- An interfering residual current is flowing through the clamp
- There is a PGH locating pulse acting on the clamp

• No CT connected

Measuring clamp or measuring current transformer not connected or faulty.

• Error $I_{\#L}$ (can only be indicated while a measurement is in progress):

- Low frequency interference, measurement not possible
- EDS195PM hardware faulty

• $I_{\#n} > 10 \text{ A} / I_{\#n} > 1 \text{ A}$

There is a residual current $> 10 \text{ A}$ or $> 1 \text{ A}$ flowing through the measuring clamp. In this case it is not possible to locate the insulation fault on the related outgoing circuit. Residual currents of this magnitude in an IT system can be caused by large system leakage capacitances or multiple insulation faults. It is therefore possible that there is an insulation fault on this outgoing circuit even with this alarm message.

6.12.5 Indication of the harmonics during residual current measurement

Using the EDS195PM it is also possible to measure harmonics of the fundamental frequencies of 50 or 60 Hz.

1. Switch on the EDS195PM by pressing the \cup button.
The device is in the EDS mode. $I_{\#L}$ appears in the first line of the display.
2. Check correct setting for the selection of the clamp or current transformer on the display, correct if necessary.
3. Select RCM mode ($I_{\Delta n}$) using the $I_{\#L} | I_{\#n}$ button.
4. Make the following settings:
 - Check response value on menu 2.3 (Settings $I_{\Delta n}$) and change if necessary.
 - Check system frequency on menu 2.6 (Settings $I_{\Delta n}$) and change if necessary.
 - Activate measurement of the harmonics on menu 2.7 (Settings > Harmonics).
 - Select the required harmonics on menu 4.

The EDS195PM indicates the harmonics of a residual current at each measuring point. If the residual current is greater than the response value set, the **ALARM** LED flashes and the measured value is displayed. If the buzzer is activated, there is also an audible signal.

After the activation of the harmonics in menu 2.7, the harmonic with the greatest amplitude and the total harmonic distortion in % can be seen in the standard display with the menu closed.

6.13 Coupling device AGE185 for higher system voltages

This option is available for the variants EDS3090PG, EDS3090PG-13 and EDS3096PG with the locating current injectors PGH185 and PGH186. The coupling device AGE185 expands the nominal voltage range of the insulation fault location system EDS309...

The AGE185 reduces the losses in the locating current injector PGH18... As a result it makes it possible to connect the PGH18... to nominal system voltages up to AC 790 V or DC 960 V.



DANGER

Risk of electric shock

Touching live, uninsulated wires can cause death or serious injury.

- Avoid any physical contact with live wires.
- Follow the rules for working on electrical systems.

Installation, connection and commissioning

The two cable ends of the AGE185 can be connected to the system's PE terminals and the PE socket of the PGH186 as required and according to the local conditions.; it is not necessary to observe polarity.

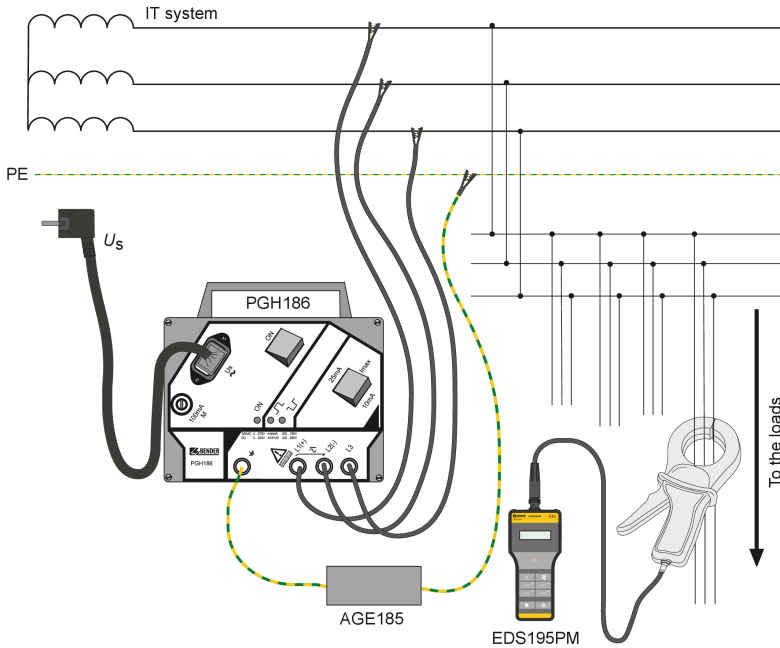

Figure 6-3: Connection diagram EDS309... with AGE185

6.14 Power supply for the EDS195PM

- Supply
 - non-rechargeable batteries: 3 × AA cells of 1.5 V or
 - rechargeable batteries: 3 × AA NiMH cells of 1.2 V
- The power supply unit is not allowed to be connected with non-rechargeable batteries!
- On the connection of a power supply unit, 3 rechargeable batteries must be inserted.
- Rechargeable battery charging time: ≤ 5 h

6.14.1 Displaying charge state

The display can indicate 4 different charge states: 100 %, 66 %, 33 % and a flashing empty battery symbol.

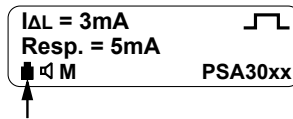

6.14.2 Changing batteries

The battery compartment is on the rear of the EDS195PM. The EDS195PM retains settings when changing batteries.

1. Undo 2 screws in the cover on the rear, remove cover.
2. Remove the old batteries.
3. Insert new batteries, observing polarity.
4. Close the cover.

6.14.3 Power supply unit supplied



ADVICE

Incorrect triggering due to wrong measuring values

The power supply unit influences the measuring accuracy of EDS195PM.

- *Never connect the power supply unit during measurements.*

The power supply unit is intended to charge the rechargeable batteries in the EDS195PM.

6.15 Additional fault location information using the EDS309x

Sometimes it is not possible to find a fault as described in "Practical usage", page 41. The ISOMETER® indicates an insulation fault, but the fault cannot be located. Therefore, this chapter provides additional information for fault location with the EDS309x.



Before travelling onsite

Ensure that you have all the required equipment for troubleshooting.

Required equipment

- EDS3090PG (B91082021)
- EDS3091PG (B91082023)
- PSA3165 (B980852)
- AGE185 (B980305)
- EDS-SET (B91082007)
- EDS195PM (B91082041)
- Portable oscilloscope

If you need to accurately measure insulation resistance and generate a test current of 50 mA, the following equipment is required:

- IRDH575B1- 435 (B91065500)
- IRDH575B2- 435 (B91065503)

- iso685-X-P
- isoxx1685xP

6.15.1 Collecting and analysing information

Before taking measurements:

- **Obtain and scrutinize the plant drawings/layout:**
 - Make sure you familiarize yourself with all the outlets/measuring points and where they are.
- **Determine the system type:**
 - Main electricity grid (use the EDS3090PG)
 - Voltage controlled network (use the EDS3091PG)
- **Speak to as many people as possible:**
 - Ask when and how (under what circumstances) did the fault occur?
 - Find out what changes (if any) were made to the installation before the fault occurred by asking the following questions:
 - Were any new components added (system extension)?
 - Were any components replaced?

6.15.2 Taking measurements

Use the PGH... to generate a defined test current. The magnitude of the current depends on the insulation fault present and the system voltage.

i *Ensure there are no system components or loads (e.g. relays) in which the test current could cause a reaction that could be dangerous. Use a low test current to begin with and increase as required.*

The test current flows from the test current generator through the live conductors to the insulation fault by the shortest route. This locating current pulse is detected by the measuring clamps or measuring current transformers in the insulation fault path and is indicated by the EDS195PM insulation fault locator.

If the location of the fault has not been determined after the standard measurements and questions (see Practical usage), consider the following:

- Are there outlets that have been missed? Check the plant layout again.
- Are we looking in the right location for the fault? The fault can also be inside the plant, on the distribution or sub-distribution lines, for example, or in the transformers, charging rectifiers or batteries of the power supply.
- Sometimes the return path of the current is not clear because of leakage capacitances, and other parallel faults or system interferences can result in reduced sensitivity. Interferences can also occur due to low-frequency residual currents or magnetic fields in the environment.

Therefore, the service engineer must visually inspect and analyse the signal. This is done using the EDS195PM fault locator and a portable oscilloscope. The EDS195PM has a measuring signal output that can be connected directly to the portable oscilloscope via a 50 Ω coaxial cable (RG58).

Measuring signal output

Measuring signal input



EDS195PM

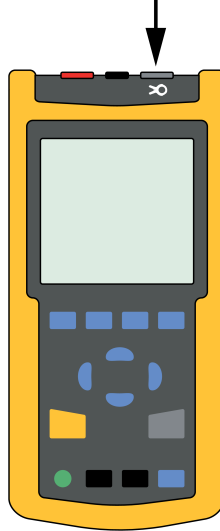

portable oscilloscope

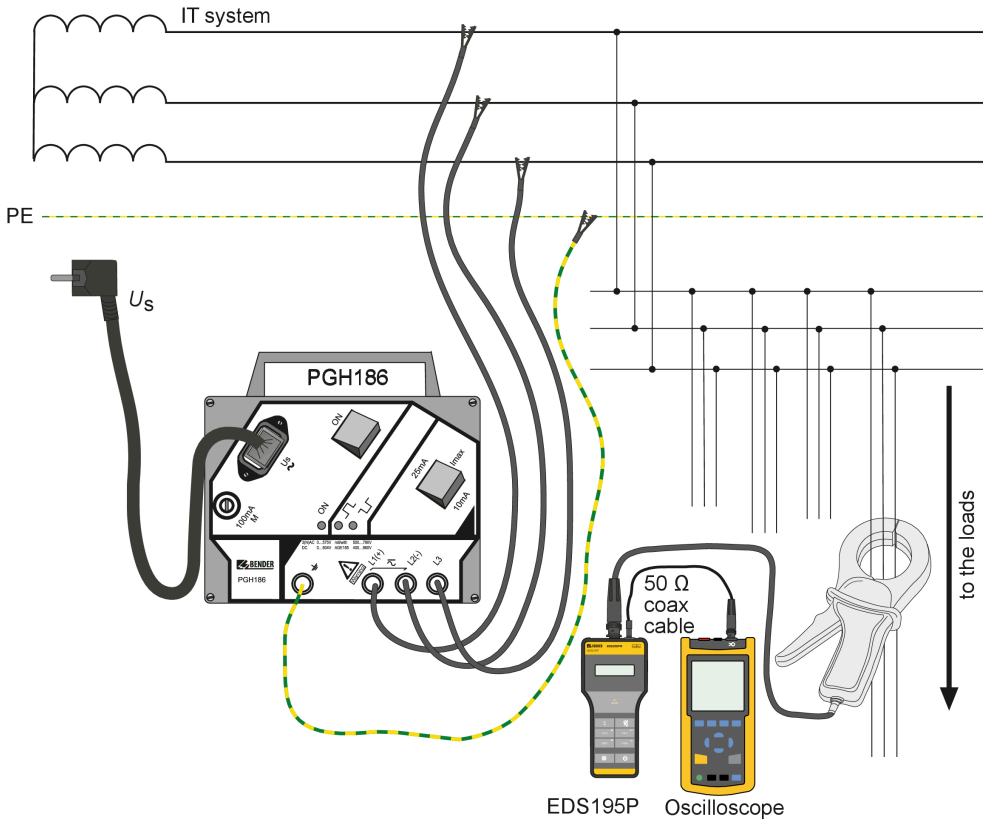

Figure 6-4: EDS309... connectivity in an IT system

In diode decoupled systems, parallel test signals can also be visually inspected:

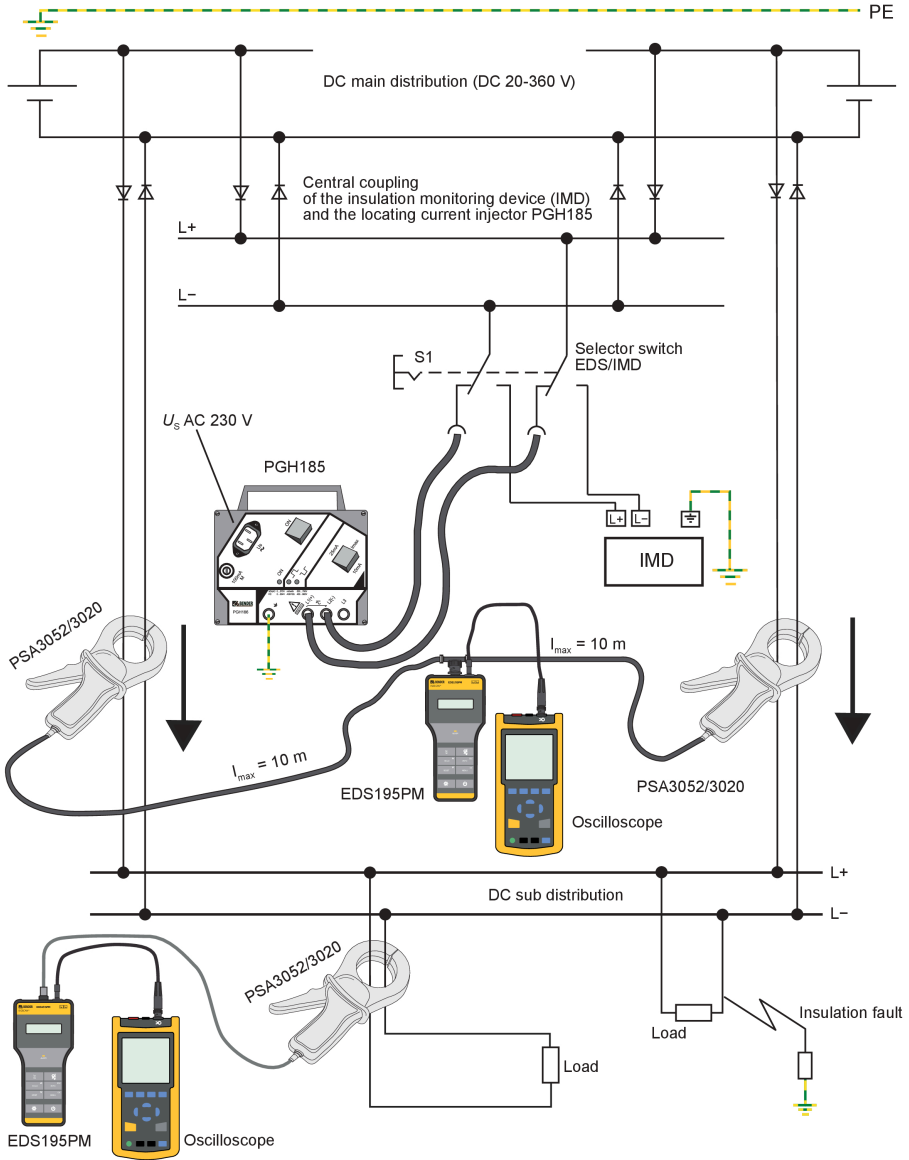

Figure 6-5: Insulation fault location in a diode-decoupled DC system (connection diagram)

A typical measured signal in systems without any interference is shown below (left). The amplitude of the signal is dependent on the magnitude of the test current. The alarm notification and the square wave pulse signalling a detected test current can be seen at the upper right-hand corner of the EDS195PM display (right).

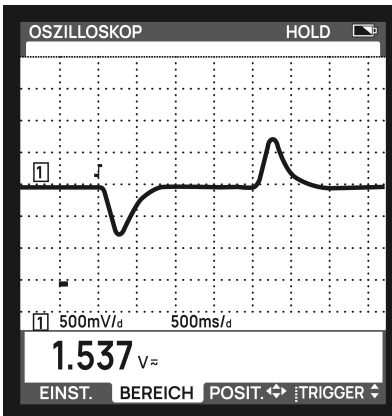
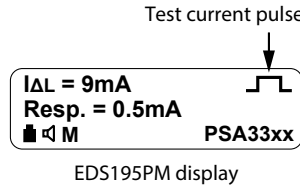

Figure 6-6: Oscilloscope signal without disturbance in the system



The measurement signal can, however, be affected by any number of problems (like those mentioned previously) so that the normal alarm notification is not given. In this case a visual detection of the signal by the portable oscilloscope is possible. The example below (left) shows a low-frequency disturbance. No alarm message appears on the EDS195PM display. Instead of the usual timer or the square wave pulse that signals a detected test current, only the --- symbol is visible in the upper right-hand corner.

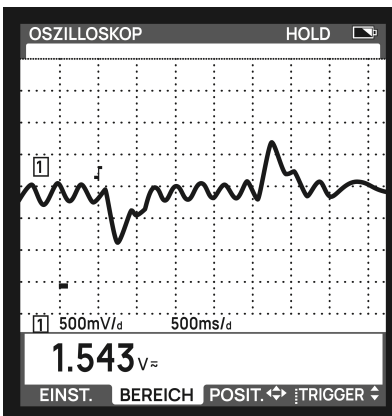
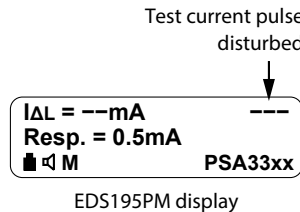

Figure 6-7: Oscilloscope signal with disturbance in the system



This method makes it easy to follow the test signal.

If the test signal displayed on the oscilloscope is very small, the following options are available:

- Increase the test current in the **main circuits** to 50 mA by means of IRDH575, iso685-x-P or isoxx1685xP.
- Increase the test current in **control circuits** to 10 mA or 25 mA by means of the PGH185 under the following condition:
 - This should be done only in the case of an earth fault so that there is no influence on a controller. For this purpose, the following should be checked:
 - The ISOMETER® displays a value of < 1 kΩ.
 - The voltage measurement on a line of all active line conductors (L–, L+, or L1, L2, L3, N) to earth (PE) must be < 1 V.
- The PSA33xx is typically used for control circuits into which a test current of up to 2.5 mA has been injected. However, in connection with the EDS195PM, test currents of up to 10 mA can also be measured. With this method higher sensitivity is achieved and a clearer measurement signal displayed is on the oscilloscope.

i

Fault finding in diode decoupled DC systems

If the distance between the switchgear is too great to allow the use of two parallel measuring clamps, proceed as follows:

- *Use only one measuring clamp.*
- *Experience has shown that the signal in a system with a disturbance is similar to that shown in Fig. 6-7: Oscilloscope signal with disturbance in the system, and often the disturbance can be visually detected with an oscilloscope.*
- *If necessary, increase the test current as described above.*

i

Fault finding in AC systems

If the insulation fault cannot be located using the $I_{\Delta L}$ function, then measure the differential current using the $I_{\Delta n}$ function; this is possible, at least in the case of an earth fault. The output with the highest differential current amplitude is usually the one where the fault is located. In exceptional cases, the output with the highest differential current amplitude is also the one with the highest leakage capacitance.

NOTICE: *In exceptional cases, the output with the highest differential current amplitude is also the one with the highest leakage capacitance. In this case, the differential current amplitude becomes smaller the further away the measuring location is from the IT system supply.*

7 Technical data

7.1 Technical data EDS309... system

Valid for PGH18..., EDS195PM, AGE185

Environment/EMC

EMC	IEC 61326-2-4
Operating temperature	-10...+55 °C

Climatic classes acc. to IEC 60721:

Stationary use (IEC 60721-3-3)	3K22
Transport (IEC 60721-3-2)	2K11
Long-term storage (IEC 60721-3-1)	1K22

Classification of mechanical conditions acc. to IEC 60721:

Stationary use (IEC 60721-3-3)	3M11
Transport (IEC 60721-3-2)	2M4
Long-term storage (IEC 60721-3-1)	1M12

Other

Operating mode	continuous operation
Position in normal use	any
Weight EDS309...	≤ 7000 g
Weight EDS309... with PSA3165	≤ 8500 g
Weight EDS3092	≤ 9000 g
Dimensions, case W × H × D	430 × 340 × 155 mm

7.2 Technical data PGH18...

Insulation coordination according to IEC 60664-1 / IEC 60664-3

Rated voltage	AC 500 V
Rated surge voltage	4 kV
Degree of pollution	3

Nominal system voltage U_n

PGH183	AC 42...460 Hz; 20...265 V DC 20...308 V
PGH185	(3)AC 42...460 Hz; 20...575 V DC 20...504 V
PGH186	(3)AC 42...460 Hz; 0...575 V DC 0...504 V

Supply voltage

Supply voltage U_S	AC 50...60 Hz; 230 V
Operating range of U_S	0.85...1.15 × U_S
Supply voltage U_S version -13	AC 50...60 Hz; 90...132 V
Power consumption	
PGH 183, PGH 185	≤ 3 VA
PGH 186	≤ 6 VA

Locating current

PGH183	selectable: 1 mA / 2.5 mA
PGH185/186	selectable: 10 mA / 25 mA
Test cycle	2 s
Pause duration	4 s

Locating voltage

PGH186	DC 50 V
--------	---------

Other

Degree of protection of built-in components DIN EN 60529 (VDE 0470-1)	IP40
Enclosure material	ABS plastic
Flammability class	UL 94 V-0
Weight	≤ 700 g
Dimensions	160 × 148 × 81 mm

7.3 Technical data EDS195P(M)

(*) = Factory settings

Insulation coordination according to IEC 60664-1 / IEC 60664-3

Rated voltage	50 V
Rated surge voltage	0.8 kV
Degree of pollution	3

Supply voltage

Power supply U_S	Rechargeable batteries, batteries or USB power supply unit
Rechargeable batteries	3 × NiMH R6 AA – 1.2 V – min. 2000 mAh
Operating time (without display lighting)	≤ 150 h
Charging time	≤ 5 h

Batteries 3 × LR6 AA – 1.5 V

USB power supply unit:

Primary	100...240 V; 50...60 Hz
Secondary	DC 5 V; ± 10 %
Power consumption	≤0.5 W

Measuring circuit, insulation fault location

Nominal system voltage with uninsulated conductors with measuring clamp up to 600 V

Rated frequency DC, 42...2000 Hz

Main circuit ($I_{Lmax} = 50$ mA):

Measuring range	2 mA...50 mA
Measuring clamps	PSA3020, PSA3052, PSA3165
Response sensitivity $I_{\Delta L}$ adjustable	2...10 mA (5 mA)*
Operating uncertainty	±30 % / ±2 mA of nominal value

Control circuit ($I_{Lmax} = 5$ mA)

Measuring range	0.2...5 mA
Measuring clamps	PSA3320, PSA3352
Response sensitivity $I_{\Delta L}$ adjustable	0.2...1.0 mA (0.5 mA)*
Operating uncertainty 0.2...0.9 mA	±30 % / ±0.2 mA of the nominal value
Operating uncertainty 1...5 mA	±30 % / ±2 mA of the nominal value

Measuring circuit, residual current

Measuring clamps PSA3020, PSA3052, PSA3165:

Measuring range	5 mA ... 10 A (crest factor up to 3)
Response sensitivity $I_{\Delta n}$ adjustable	10 mA ... 10 A (100 mA)*

Measuring clamps PSA3320, PSA3352:

Measuring range	2 mA ... 2 A (crest factor up to 3)
Response sensitivity $I_{\Delta n}$ adjustable	5 mA ... 1 A (100 mA)*

Frequency range 42...1000 Hz

Operating uncertainty, 42...60 Hz ±5 %

Operating uncertainty, 61...1000 Hz ±20 %

Hysteresis 20 %

Harmonics, indication can be disabled 1st to 8th harmonic

Inputs

Connection for measuring clamp	BNC socket
Connection for power supply unit (DC 5 V)	µUSB socket

Display

LCD	3 × 16 characters, switchable backlight
LED	Alarm

Other

Degree of protection of built-in components DIN EN 60529 (VDE 0470-1)	IP40
Protective class according to IEC 60947-1, DIN EN 60947-1 (VDE 0660-100)	III
Enclosure material	ABS plastic
Flammability class	UL 94 V-0
Weight	≤350 g
Software version	D399 V2.1
Dimensions W × H × D	84 × 197 × 30 mm

7.4 Technical data measuring clamps

Note: The technical data for the CTA-F-set can be found at <https://www.bender.de/en/service-support/download-area/>

Electrical safety

Standard	IEC 61010-2-030
Degree of pollution	2
System class	III
Operating voltage	600 V
Nominal insulation voltage	AC 600 V CAT III or AC 300 V CAT IV

Transformer ratio

PSA30...	10 A / 10 mA
PSA33...	1 A / 0.1 mA
PSA3165	10 A / 10 mA

Other

Degree of protection of built-in components DIN EN 60529 (VDE 0470-1)	IP40
Protective class according to IEC 60947-1, DIN EN 60947-1 (VDE 0660-100)	III
Measurement output	BNC socket
Dimensions PSA3052/3352	216 × 111 × 45 mm

Dimensions PSA3020/3320	135 × 65 × 30 mm
Dimensions PSA3165	285 × 179 × 45 mm
Permissible cable diameter PSA3052/3352	52 mm
Permissible cable diameter PSA3020/3320	20 mm
Permissible cable diameter PSA3165	115 mm
Weight PSA3052/3352	≤700 g
Weight PSA3020/3320	≤300 g
Weight PSA3165	≤1300 g

7.5 Technical data AGE185

Insulation co-ordination according to 60664-1

Rated insulation voltage	AC 1000 V
Rated impulse voltage	4 kV
Degree of pollution	3
Nominal system voltage U_n	(3)AC 42...460 Hz, 500...790 V DC 400...960 V

Other

Degree of protection of built-in components DIN EN 60529 (VDE 0470-1)	IP30
Connection type/wire	Safety laboratory connectors with green-yellow connection wire 1 mm ²
Weight	≤ 200 g
Dimensions W × H × D	88.5 × 42 × 21 mm

7.6 Standards and certifications

Observe the applicable national and international standards. The series EDS309... complies with the standards:

- DIN VDE 0100-410 (VDE 0100-410)
Low-voltage electrical installations – Part 4-41: Protection for safety – Protection against electric shock (IEC 60364-4-41, modified); German version HD 60364-4-41
- DIN EN 61557-9
Electrical safety in low voltage distribution systems up to 1000 V a.c. and 1500 V d.c. – Equipment for testing, measuring or monitoring of protective measures - Part 9: Equipment for insulation fault location in IT systems (IEC 61557-9); German version EN 61557-9
- DIN EN 61010-1; VDE 0411-1
Safety requirements for electrical equipment for measurement, control and laboratory use – Part 1: General requirements (IEC 61010-1); German version EN 61010-1



7.7 Dimension diagrams

All dimensions in mm

Aluminium case

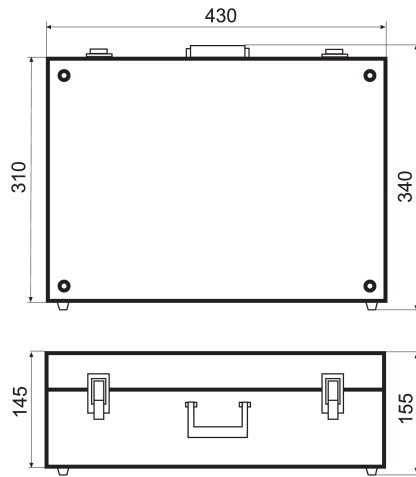

AGE185

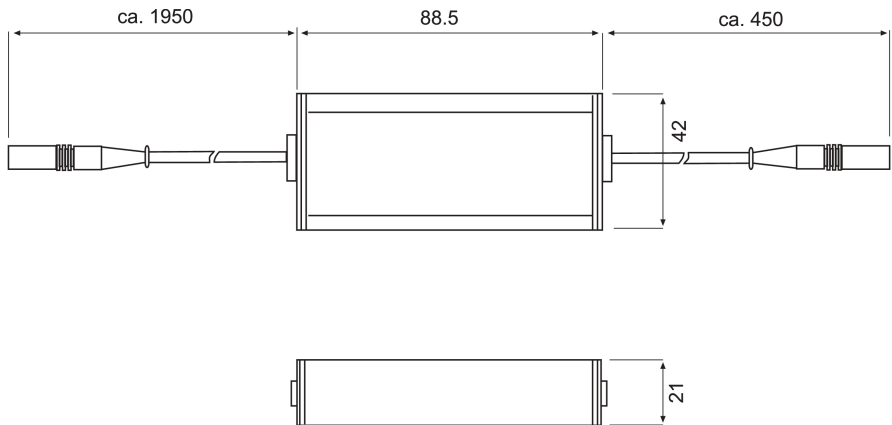

7.8 Status word

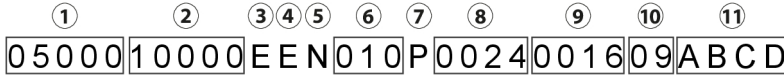

- 1 $I_{\Delta L}$ ALM [μ A]
- 2 $I_{\Delta n}$ ALM [mA]
- 3 Fault memory: E = on | A = off
- 4 Buzzer: E = on | A = off
- 5 $I_{\Delta n}$ Data logger Overwrite: J = yes | N = no
- 6 $I_{\Delta n}$ Data logger Change [%]
- 7 CT type
 - p = PSA30xx
 - P = PSA33xx
 - w = W/WR/WS
 - W = W/WR-8000
 - F = WF...
- 8 R_{cu} of the CT [Ω]
- 9 L of the CT [H]
- 10 LCD contrast
- 11 Error Code: Output in hex format, binary coded

7.9 Ordering details

EDS309x

Type	Items supplied*				Supply voltage	Nominal voltage	Art. No.
	Insulation fault locator	Locating current injector	Measuring clamp 20 mm	Measuring clamp 52 mm			
EDS3090	EDS195PM		PSA3020	PSA3052			B91082026
EDS3090PG	EDS195PM	PGH185	PSA3020	PSA3052	AC 50...60 Hz, 230 V	AC 42...460 Hz, 20...575 V; DC 20...504 V	B91082021
EDS3090PG-13	EDS195PM	PGH185-13	PSA3020	PSA3052	AC 50...60 Hz, 90...132 V		B91082022
EDS3091	EDS195PM		PSA3320	PSA3352			B91082027
EDS3091PG	EDS195PM	PGH183	PSA3320	PSA3352	AC 50...60 Hz, 230 V	AC 42...460 Hz, 20...265 V; DC 20...308 V	B91082023
EDS3091PG-13	EDS195PM	PGH185-13	PSA3320	PSA3352	AC 50...60 Hz, 90...132 V		B91082024
EDS3092PG	EDS195PM	PGH183	PSA3320	PSA3352	AC 50...60 Hz, 230 V	AC 42...460 Hz, 20...265 V; DC 20...308 V	B91082030
		PGH185	PSA3020	PSA3052	AC 50...60 Hz, 230 V	AC 42...460 Hz, 20...575 V; DC 20...504 V	
EDS3096PG	EDS195PM	PGH186	PSA3020	PSA3052	AC 50...60 Hz, 230 V		B91082025
EDS3096PG-13	EDS195PM	PGH186-13	PSA3020	PSA3052	AC 50...60 Hz, 90...132 V	AC 42...460 Hz, 0...575 V; DC 0...504 V	B91082029
EDS3096PV	EDS195PM	PGH186	-	2 × PSA3052	AC 50...60 Hz, 230 V		B91082031

* Every EDS309x is supplied with a USB power supply unit and USB cable.

Optional accessories

Type	Description	Supply voltage U_s	Art. No.
AGE185	Coupling device for increasing the voltage range of the PGH185/186	AC 42...460 Hz, 500...790 V; DC 400...960 V	B980305
Adapterkabel BNCPS2	Adapter cable for operating a WF current transformer on the EDS195PM		B91082045
EDS-SET	BNC T-connector and 2 BNC cables for fault location in diode-decoupled systems		B91082007
Plug power supply with USB connector	DC 5 V for external supply of the EDS195PM via μ USB connector		A167054
PSA3165	Clamp 115 mm for EDS3090... and EDS3096...		B980852
CTAF SET	Clamp flexible for insulation fault location and differential method, with CTAF ENCLOSURE, CTAF500 BAND, CTAF1000 BAND, BNC cable, terminal, 2 × spare screws, case Only in combination with EDS195PM		B98080220
CTAF GEHÄUSE	CTAF enclosure as spare part for CTAF SET without BNC cable, with terminal and 2 × spare screws		B98110026
CTAF500 BAND	Band 500 mm as spare part for CTAF SET		B98110027
CTAF1000 BAND	Band 1000 mm as spare part for CTAF SET		B98110028

7.10 Component list

Components EDS309...

Device type	EDS195PM with accessories							PGH18... with accessories for							Measuring clamps			
	Aluminium case with carrying handle	Operating manual	Insulation fault locator	Clamping connector on 4 mm	A adapter BNC/4mm connector for CT	A adapter BNC-PS2 for WF-CT, optional	Plug power supply for EDS195PM	Locating current injector	Supply cable for PGH18...	Safety measuring cable, black	Safety measuring cable, green/yellow	Safety claw grip, black	Safety claw grip, green/yellow	Coupling device, optional (delivered with EDS3096PV only)	Measuring clamp 20 mm	Measuring clamp 52 mm	Measuring clamp 115 mm, optional	EDS SET, optional
EDS3090	1	1	EDS195PM	1	1	1	1							PSA3020	PSA3052	PSA3165	1	
EDS3090PG	1	1	EDS195PM	1	1	1	1	PGH185	1	3	1	3	1	AGE185	PSA3020	PSA3052	PSA3165	1
EDS3090PG-13	1	1	EDS195PM	1	1	1	1	PGH185-13	1	3	1	3	1	AGE185	PSA3020	PSA3052	PSA3165	1
EDS3091	1	1	EDS195PM	1	1	1	1							PSA3320	PSA3352		1	
EDS3091PG	1	1	EDS195PM	1	1	1	1	PGH183	1	3	1	3	1	PSA3320	PSA3352		1	
EDS3091PG-13	1	1	EDS195PM	1	1	1	1	PGH185-13	1	3	1	3	1	PSA3320	PSA3352		1	
EDS3092PG	1	1	EDS195PM	1	1	1	1	PGH183 PGH185	2	6	2	6	2	PSA3320 PSA3020	PSA3352 PSA3052		1	
EDS3096PG	1	1	EDS195PM	1	1	1	1	PGH186	1	3	1	3	1	AGE185	PSA3020	PSA3052	PSA3165	1
EDS3096PG-13	1	1	EDS195PM	1	1	1	1	PGH186-13	1	3	1	3	1	AGE185	PSA3020	PSA3052	PSA3165	1
EDS3096PV	1	1	EDS195PM	-	-	-	1	PGH186	1	3	1	3	1	AGE185	-	2 × PSA3052	-	-

7.11 Change log

Date	Document version	Software version	Changes / state
02.2022	07	-	Editorial revision <ul style="list-style-type: none"> • Climatic classes updated • CE + UKCA added • Change log added
03.2025	08	D399 V2.1	Transfer to editorial system incl. editorial revision and new CI
06.2025	09		EDS195P(M) customised Note added to graphic "Connect the locating current injector PGH186 as follows:", page 29



Bender GmbH & Co. KG

Londorfer Straße 65
35305 Grünberg
Germany

Tel.: +49 6401 807-0
info@bender.de
www.bender.de

All rights reserved.
Reprinting and duplicating only with
permission of the publisher.



© Bender GmbH & Co. KG, Germany
Subject to change!
The specified standards take into
account the edition valid until 06.2025
unless otherwise indicated.