

# KINAX WT720

## absolute, programmable angular position transmitter

### For industrial applications in rough environments

KINAX WT720 is a robust, absolute angular position transmitter, which is particularly suited to applications in rough environments due to its unique capacitive measuring principle. It acquires the angular position of a shaft in a non-contact manner and converts it into an impressed direct current proportional to the measured value.

The high mechanical capacity, the robust design, easy assembly via synchronous flange or flange adapter, the variety of connection options and free parameterising offer the highest degree of quality and flexibility in application and installation.

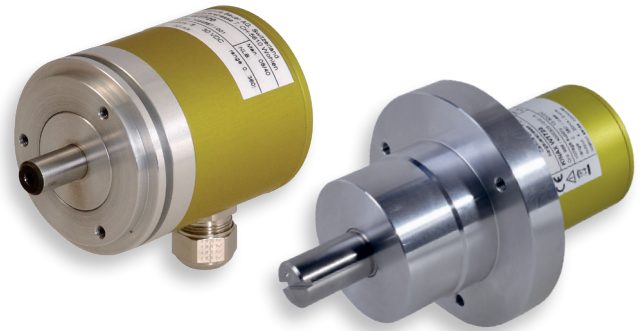

### Your customer benefit

#### LOW LIFE-CYCLE COSTS DUE TO:

##### TESTED TOP QUALITY

- Waterproof and dustproof IP67/IP69K
- With maritime execution (formerly GL, Germanischer Lloyd)
- Explosion protection acc. ATEX and IECEx intrinsic safety "ia" (gas and dust) and protection by housing "tb" (dust)

##### SAFE, FREE OF MAINTENANCE

- Compact industrial housing
- Resistant to high mechanical stress due to its robust design and high-quality materials
- High immunity against magnetic fields
- Safe electrical connection and reliability due to spring-type push terminal and reverse voltage protection

##### EASY AND FAST COMMISSIONING

- Any installation position
- Standard synchronous flange and flange-adapter
- 2-wire connection with cable gland or M12 sensor plug
- Free on-site parameterising

### Technical data

#### General

Measured quantity: Angle of rotation  
 Measuring principle: Capacitive method

#### Measuring input

Angle measuring range: Programmable between 0 ... 360°  
 Drive shaft diameter: Ø 10 mm [0.394"]  
 Ø 19 mm [0.748"] with flange adapter  
 Starting torque: max. 0.03 Nm [4.248 in-oz]  
 max. 0.04 Nm [5.664 in-oz] with flange adapter  
 Sense of rotation: Adjustable

#### Measuring output

Output variable  $I_A$ : Load-independent DC current, proportional to the input angle  
 Standard range: 4 ... 20 mA, 2-wire protected against wrong polarity

Power supply:

Standard non Ex:  
 nominal voltage 24 VDC  $\begin{matrix} +30\% \\ -50\% \end{matrix}$

Explosion protection intrinsic ia:  
 input voltage  $U_i$ : 12 ... 30VDC  
 max. input current  $I_i$ : 160mA  
 max. input power  $P_i$ : 1W  
 max. internal capacitance  $C_i$ : 22nF  
 max. internal inductance  $L_i$ : 7.3 µH

Explosion prevention (Protection by enclosure) tb:  
 nominal voltage 24 VDC  $\begin{matrix} +30\% \\ -50\% \end{matrix}$

Response time:

< 3.5 ms

External resistance: (load)

$$R_{\text{ext.max.}} [\text{k}\Omega] = \frac{H [\text{V}]-12\text{V}}{I_A [\text{mA}]}$$

H = Power supply

$I_A$  = Output signal end value

# KINAX WT720

## absolute, programmable angular position transmitter

### Accuracy data

Absolute precision:  $\pm 0,5\%$  at 360°

Precision with errors:

90°	60°	30°
$\pm 0,67\%$	$\pm 0,78\%$	$\pm 1,12\%$

Additional errors (cumulative):

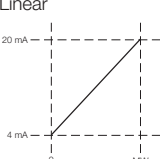
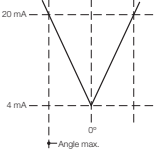
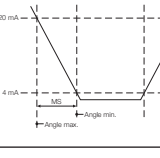
Output characteristic	Definition	Additional error
	Programmed Angle max. = MW Angle min. = 0°	$f_{Add} = \left( \frac{0,2^\circ}{MW} \times 100 - 0,05 \right)$ $[f_{Add}] = \%$
	e.g. at MW=90°: $f = f_{Add} + f_{Abs} = 0,15\% + 0,5\% = 0,65\%$	
	Programmed Angle max. = MW Angle min. = 0°	$f_{Add} = \left( \frac{0,3^\circ}{MW} \times 100 \right)$ $[f_{Add}] = \%$
	MS = (angle max.) - (angle min.) angle max. = $\pm$ final angle angle min. = $> 0^\circ$	$f_{Add} = \left( \frac{0,3^\circ}{MS} \times 100 \right)$ $[f_{Add}] = \%$

Resolution:  $\pm 0,1^\circ$

Reproducibility:  $< 0,1^\circ$

Influence of temperature  
 output current  
 (-40...+85°C):  $\pm 0,04\% / 10K$   
 [-40 ... +185°F]

### Installation data

Material: Front: aluminium (AW-6023)  
 Back: aluminium (AW-6023) anodized  
 Shaft: rust-proof, (1.4035 hardened steel)

Mounting position: Any

Connections: 3-pin spring-type terminal block or sensor plug connector metal (M12 x 1, 4 poles / only for non Ex version)

Weight: Approx. 360 g

Admissible static loading of shaft:

WT720 Standard	WT720 with adapter flange
80 N (radial)	120 N (radial)
40 N (axial)	40 N (axial)

Clearance influence:  $\pm 0,1\%$

### Regulations

Spurious radiation: EN 61000-6-3  
 Immunity: EN 61000-6-2  
 Degree of pollution: 2  
 Admissible common-mode voltage: 100 V AC, CATII  
 Test voltage: 750 V DC, 1 min.  
 All connections against housing  
 Housing protection: IP 67 acc. to EN 60529  
 IP 69k acc. to EN 40050-9

### Environmental conditions

Climatic rating: Standard (Not Ex):  
 Temperature -40 ... +85 °C [-40 ... +185°F]  
 Rel. humidity  $\leq 95\%$  non-condensing  
Explosion protection:  
 Temperature -40 ... +70 °C [-40 ... +158°F]  
 Rel. humidity  $\leq 95\%$  non-condensing  
 Vibration resistance:  $\leq 100 \text{ m/s}^2 / 10 \dots 500 \text{ Hz}$  according to EN 60068-2-6  
 Shock resistance: 1000 m/s<sup>2</sup> / 11 ms according to EN 60068-2-27  
 Transportation and storage temperature: -40 ... +85 °C [-40° ... +185°F]

### Operation in potentially explosive environments:

Gas explosion prevention: Labeling: Ex ia IIC T4 Gb  
 Conform to standard: ATEX:  
 EN 60079-0:2012  
 EN 60079-11:2012  
 IECEx:  
 IEC 60079-0:2011  
 IEC 60079-11:2011-06

Type of protection: ia  
 Temperature class: T4  
 Group according to EN60079-0:2012: II

Dust explosion prevention: Labeling: Ex ia IIIC T80°C Db  
 or Ex tb IIIC T80°C Db  
 Conform to standard: ATEX:  
 EN 60079-0:2012  
 EN 60079-11:2012  
 EN 60079-31:2009

IECEx:  
 IEC 60079-0:2011  
 IEC 60079-11:2011-06  
 IEC 60079-31:2008

Type of protection: ia  
 or tb (Protection by enclosure)

max. surface temperature: 80°C

# KINAX WT720

## absolute, programmable angular position transmitter

Group according to  
EN60079-0:2012: III

### Dimensional drawing

WT720 Standard

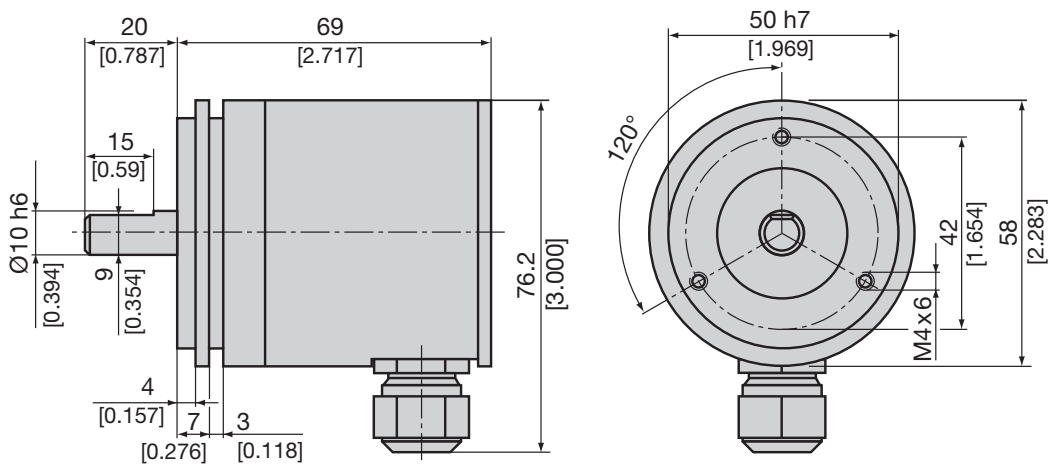

WT720 with Flange

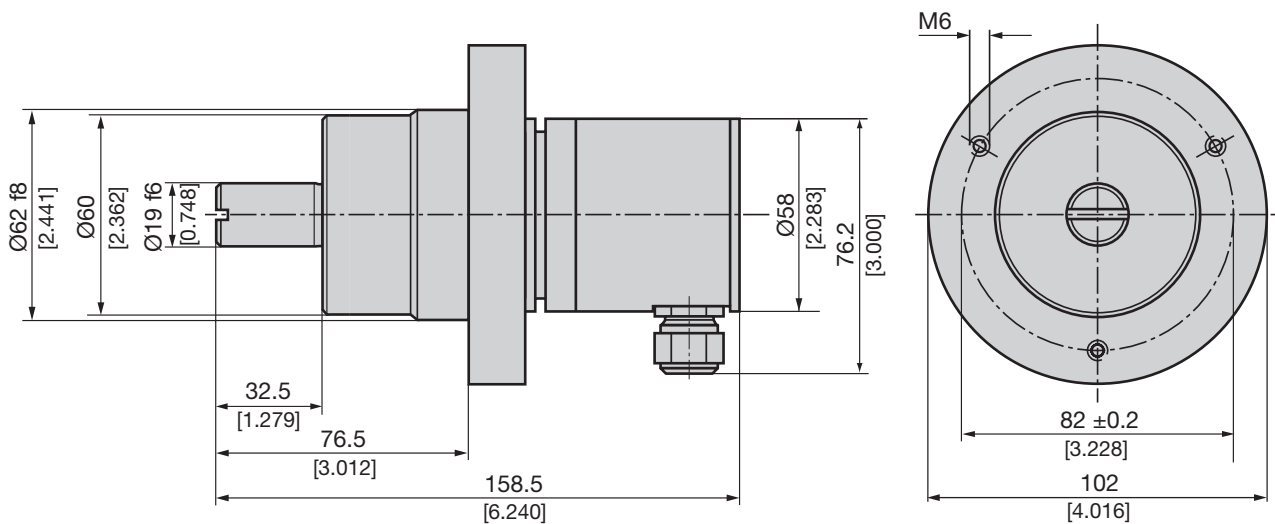

# KINAX WT720

## absolute, programmable angular position transmitter

### Mounting

All of the transmitters of this series may be mounted on the object to be measured as shown in the drawings. Screws, clamps, mounting brackets and mounting plates are not part of the scope of delivery but are available as accessories.

WT720 Standard

	Mounting	Cut-out diagram for mounting
direct		
with 3 clamps		
with mounting plate		
with mounting angle		

# KINAX WT720

## absolute, programmable angular position transmitter

WT720 with Flange

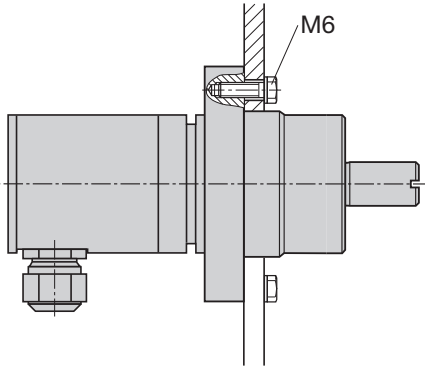
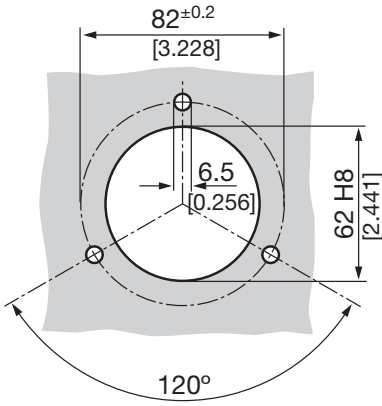
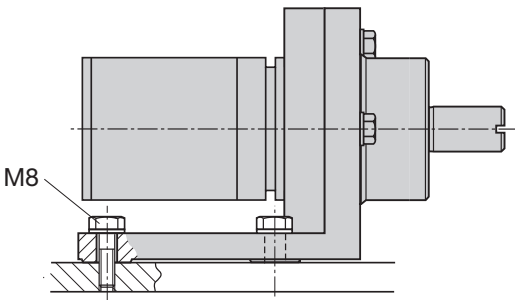
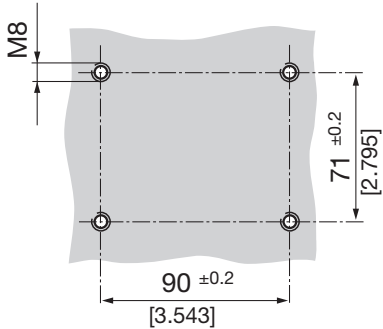
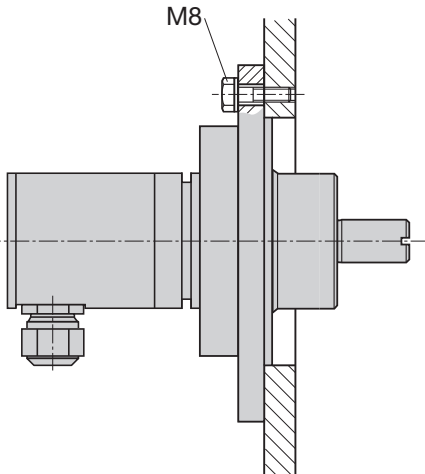
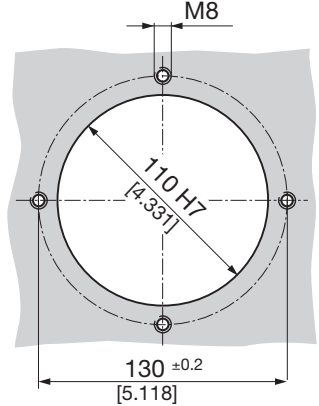
Mounting		Cut-out diagram for mounting
direct	 <p>M6</p>	 <p>82 ± 0.2 [3.228]</p> <p>62 H8 [2.441]</p> <p>6.5 [0.256]</p> <p>120°</p>
with mounting foot	 <p>M8</p>	 <p>M8</p> <p>71 ± 0.2 [2.796]</p> <p>90 ± 0.2 [3.543]</p>
with mounting flange	 <p>M8</p>	 <p>M8</p> <p>110 H7 [4.331]</p> <p>130 ± 0.2 [5.118]</p>

# KINAX WT720

## absolute, programmable angular position transmitter

### Electrical connections

The electrical wires are connected to the transmitter via an M12 x 1 / 4-pole plug connector (only in the non-Ex variant) or an M16 x 1.5 cable gland. The cable gland version is connected according to the connection diagram via a spring-type push terminal. The Ex variant may only be used with the threaded cable connection supplied.

Permissible cable-Ø: NEx 6-10 mm  
Ex 4-8 mm  
max. conductor cross-section: 2,5 mm<sup>2</sup>

Connection allocation spring-type terminal block

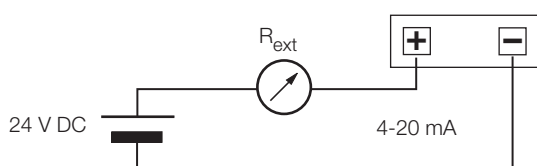

Connection allocation plug (only for non Ex version)

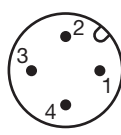
	Pin	Plug
	1	+
	2	-
	3	not connected
	4	⊥

### Programming

Parameters may be set by keys and DIP switches right at the device. Zero point, span and direction of rotation are set independently of each other. This facilitates the adjustment in commissioning considerably.

In case of an order with a measuring range parameterised at the factory, the zero point may be set by a key while the defined span is preserved.

The factory setting can always be restored in case of maloperation.

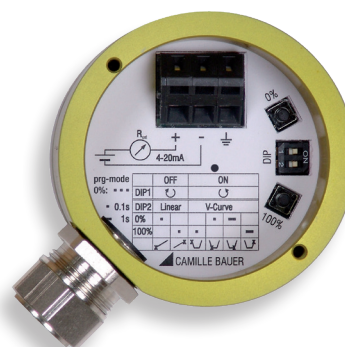

### Specification and ordering information

Description	Blocking code	No-go with blocking code	Article No./ Feature
<b>KINAX WT720</b>			720 -
<b>1. Version</b>			
Standard			1
ATEX EX II 2G Ex ia IIC T4 Gb II 2D Ex ia IIIC T80°C Db	A		2
ATEX EX II 2D Ex tb IIIC T80°C Db	A		3
IECEX Ex ia IIC T4 Gb Ex ia IIIC T80°C Db	A		4
IECEX Ex tb IIIC T80°C Db	A		5
<b>2. Angle area mechanically</b>			
Single-Turn (360°)			1

# KINAX WT720

## absolute, programmable angular position transmitter

Description	Blocking code	No-go with blocking code	Article No./ Feature
<b>KINAX WT720</b> <span style="float: right;">Order code 720 - xxxx xxxx xx</span>			720 -
<b>3. Drive shaft</b>			
Standard, shaft Ø 10 mm [0.393"]			1
Flange, shaft Ø 19 mm [0.748"]			2
<b>4. Output variable</b>			
Current, 4...20 mA, two-wire			1
<b>5. Electrical connections</b>			
Gland standard			1
Gland with increased strain relief			2
Sensor plug M12		A	3
<b>6. Test protocols</b>			
Without protocols			0
Protocol German			1
Protocol English			2
<b>7. Interface</b>			
Without a programmable interface			0
<b>8. Direction of rotation</b>			
Direction of rotation clockwise	J		0
Direction of rotation counter-clockwise	J, G		1
V-characteristic	K, G		2
<b>9. Measuring range</b>			
Basic configuration (linear, 0 ... 360°)			K, G
[°angle], 0...end value:		Switching point:	K
V-characteristic	vmax1:	vmin1:	J
[± ° angle]	vmax2:	vmin2:	
<b>10. Climatic rating / Marine version</b>			
Normal climatic rating (rel. humidity annual average ≤ 90 %)			0
Increased climatic rating (rel. humidity annual average ≤ 95 %)			1
Maritime execution (formerly Germ. Lloyd)			G

# KINAX WT720

## absolute, programmable angular position transmitter



### Accessories

Article	Article-Nr.
Plug connector for M12 sensor plug, 5 poles	168 105
Kit mounting clamp	157 364
Mounting angle for WT720 Standard	168 204
Mounting plate WT720 Standard	168 212
Mounting foot for WT720 with Flange	997 182
Mounting flange for WT720 with Flange	997 190
Bellow coupling BKXK2429 Ø6/10mm	164 773
Bellow coupling BKXK3030 Ø10/8mm	164 799
Bellow coupling BKXK3030 Ø10/10mm	164 806
Bellow coupling BKXK3030 Ø10/12mm	164 814
Bellow coupling BKXK3030 Ø10/14mm	164 822
Bellow coupling BKXK3030 Ø10/16mm	164 830
Helical coupling WKAK2532 Ø 6/10mm	164 898
Helical coupling WKAK2532 Ø 10/8mm	164 913
Helical coupling WKAK2532 Ø 10/10mm	164 921
Helical coupling WKAK2532 Ø 10/12mm	164 939
Spring washer coupling FSXK3027 Ø 6/10mm	165 002
Spring washer coupling FSXK3027 Ø10/10mm	165 010
Spring washer coupling FSXK3027 Ø 6/12mm	165 028
Spring washer coupling FSXK3850 Ø 10/10mm	165 052
Spring washer coupling FSXK3850 Ø 10/12mm	165 060





### Scope of delivery

- 1 Absolute, programmable transmitter KINAX WT720 (according to Order)
- 1 Operating Instruction german, english, french (156796)

### Approvals

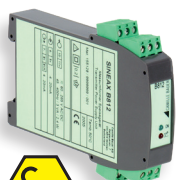
Approval	Identification
 Explosion protection according to IECEx	Ex ia IIC T4 Gb Ex ia IIIC T80°C Db Ex tb IIIC T80°C Db
 Explosion protection according to ATEX	Ex II 2G Ex ia IIC T4 Gb Ex II 2D Ex ia IIIC T80°C Db Ex II 2D Ex tb IIIC T80°C Db

You find power supply units for KINAX WT720 in our process instrumentation product range.

SINEAX B812	SINEAX B811
1-channel power supply unit	1-channel power supply unit
to feed 2-wire transmitters	
 	 

 **CAMILLE BAUER**

Camille Bauer Metrawatt AG  
 Aargauerstrasse 7  
 CH-5610 Wohlen / Switzerland  
 Telefon: +41 56 618 21 11  
 Telefax: +41 56 618 21 21  
 info@cbmag.com  
 www.camillebauer.com